

# ***INTELLISPEC™***

## **Series V Operator's Guide (5.6)**

**Pressco Technology Inc.**

**79374 Rev. 02**



Original Instructions

---

© 2019 Pressco Technology Inc. All rights reserved.

No part of this manual may be reproduced or transmitted in any form or by any means, electronic or mechanical, including photocopying and recording, for any purpose, without the express written permission of Pressco Technology Inc.

The contents of this manual are furnished for informational use only, are subject to change without notice, and should not be construed as a commitment by Pressco Technology Inc.

Written and designed at:

Pressco Technology Inc. World Headquarters

29200 Aurora Road

Cleveland, OH USA 44139-1847

TEL +1-440-498-2600

FAX +1-440-498-2615

[www.pressco.com](http://www.pressco.com)

Business Hours: Monday - Friday, 8:00am - 5:00pm Eastern Time

**Customer Support:**

24/ 7 Customer Support (for urgent system help): +1-440-498-2000

**e-mail:** Schedule a service visit: [dispatch@pressco.com](mailto:dispatch@pressco.com) (*mailto:dispatch@pressco.com*)

Request technical support and remote support: [techsupport@pressco.com](mailto:techsupport@pressco.com) (*mailto:techsupport@pressco.com*)

Customer Service Fax: +1-440-498-4761

# Table of Contents

---

<b>Chapter 1 Introduction</b> .....	<b>7</b>
Welcome!.....	7
About this Operator's Guide .....	7
Typographical Conventions.....	7
Static Discharge Protection .....	8
<b>Chapter 2 EU Declarations of Conformity</b> .....	<b>9</b>
Declaration of Conformity - Intellispec System .....	9
Declaration of Conformity - CSL System .....	10
Declaration of Conformity - FHCP3X-EZ System (MS).....	11
Declaration of Conformity - FHCP3X-EZ System (EMC).....	12
Declaration of Conformity - Cluster Box .....	13
Declaration of Conformity - Embedded Cluster Box.....	14
Declaration of Conformity - CPX Inspection Module .....	15
Declaration of Conformity - Intellimass .....	16
<b>Chapter 3 Safety Information</b> .....	<b>17</b>
Health Warnings - Photosensitive Epilepsy .....	17
Symbols.....	18
Warning Devices .....	19
Residual Risk .....	20
Intended Use.....	20
Prohibited Use .....	20
Personal Protective Equipment .....	20
Personnel Safety .....	21
Lifting heavy objects .....	22
Authorized Users.....	23
Spare Parts Usage .....	23
<b>Chapter 4 System Specifications</b> .....	<b>25</b>
Environmental conditions.....	25
Specifications .....	25
<b>Chapter 5 Installation and Wiring</b> .....	<b>37</b>
Shipping and Handling .....	37
Recommendations prior to installation .....	37
System Block Diagram - BNS .....	38
System Block Diagram - Integrated Tunnel.....	39
Assembly, location, and mounting requirements.....	39
User Interface external connections.....	42
Chromapulse module external connections .....	47
Cluster box external connections .....	48
Commissioning.....	56
<b>Chapter 6 Operating the Intellispec Series V System</b> .....	<b>59</b>
Power Up .....	59
Online / Offline .....	61
Part Changeover .....	61

Exiting the Intellispec software.....	61
<b>Chapter 7 Intellispec cabinet and user interface .....</b>	<b>63</b>
User interface input devices .....	63
<b>Chapter 8 Software Overview .....</b>	<b>67</b>
User Interface Display - Four Levels.....	67
Statistics menu.....	69
On Screen Keyboard (OSK).....	70
Menu Toolbar .....	71
<b>Chapter 9 User Accounts and Login information.....</b>	<b>73</b>
Log in and log out.....	73
Switch users .....	73
Change your password.....	73
<b>Chapter 10 Alarms.....</b>	<b>75</b>
View/ Clear Alarms .....	75
System Alarms - Description and Configuration .....	77
Lane Alarms - Brief Description .....	78
Sensor Alarms - Brief Description .....	79
Rejector Alarms - Brief Description.....	80
Machine Part Alarms - Brief Description.....	81
Machine Part Alarms - View/Clear.....	82
<b>Chapter 11 Graphs and Image Displays .....</b>	<b>83</b>
Trend Graphs .....	83
Machine Part Graphs .....	83
Sort Data in Graphs.....	84
Statistics Grid .....	86
Reject Images.....	88
Inspections graph.....	89
Walk By Graphic.....	89
Freeze on Defect .....	90
Freeze on Defect Setup menu.....	93
Freeze on Defect Options menu .....	95
Saving Images .....	95
Save Images Through the Sensor Menu .....	96
Auto-Save Images .....	96
Save Reject Images .....	97
Take Screen Shot.....	97
<b>Chapter 12 Tools menu.....</b>	<b>99</b>
Tools menu - System Overview Screen.....	99
Log Reader .....	99
Tools menu - Lane Overview and Sensor Overview Screens .....	100
Reporting .....	100
Part Setup .....	103
Part Rate .....	103
Lane Setup .....	104
Forced Reject .....	105

<b>Chapter 13 Maintenance Frequency - Integrated Tunnel .....</b>	<b>107</b>
Cleaning the Vision Processor filter .....	108
Cleaning the Cluster Box filters .....	109
Replacing/ Cleaning the Chromapulse CP4422EV Fan Filters .....	110
Cleaning Optical Surfaces.....	111
Cleaning Glass Surfaces.....	111
Cleaning the Chromapulse Beam Splitter .....	112
Cleaning the Camera Lens.....	113
Cleaning Plastic Surfaces.....	113
Cleaning the Ellipsoidal Mirror.....	114
Cleaning the Part Detector .....	114
Cleaning the Part Detector and Reflector .....	115
Replacing Filter/ Regulator Filters.....	115
<b>Index .....</b>	<b>117</b>



# Chapter 1

## Introduction

---

### Welcome!

Congratulations on your purchase of an Intellispec system! The Intellispec is a high-speed machine vision system designed specifically for product and online process monitoring. It is a powerful tool that provides inspection much more reliably than the human eye or sampling methods. The latest PC technology, powerful inspection algorithms, online adjustment capability, and inspection data storage allow the Intellispec to automatically inspect parts with extreme accuracy on high-speed lines.

The Intellispec will help you provide the highest quality of products shipped to your customers.

---

### About this Operator's Guide

This Operator's Guide provides operating instructions for the Intellispec vision system. It provides the necessary information to operate an Intellispec that is properly installed and programmed. This guide is not a programming nor hardware maintenance guide. Programming, maintenance, and system setup require specialized training. This training is available from Pressco and may be conducted at your plant or at Pressco in Cleveland Ohio, USA. For more information, **contact Pressco's** (on page 2) training department.

This Operator's Guide:

- Is considered an integral part of the system and should be kept handy for future reference as long as the system is being used in your plant.
- Is your responsibility to keep in good condition, in a dry place, and ready for consultation by the **authorized users** (on page 23) of the system.
- Contains the technology implemented at the time of selling and supplying the system and shall not be considered inadequate in case of technological enhancements in the machine or in the manual's illustrations.

Related books include:

- Intellispec Series V Software User's Guide which contains administration and programming information
  - Intellispec Series V Hardware Guide which contains servicing information
- 

### Typographical Conventions

Following is a list of typographical conventions used in this manual:

- **Bold type** indicates a topic heading or an important item or statement.
- *Italicized type* indicates emphasis.
- Names of main components and system control signals have the first letter of each word capitalized. For example: Processor Cabinet.
- Danger messages appear as shown below:



Danger - Danger messages alert you to specific conditions that can cause serious or fatal personal injury. Danger messages give you important information which must be observed to prevent injury.

---



Caution - Caution messages indicate important information which must be observed to prevent: loss of data, poor system performance, or equipment damage.

---

---

❖ *Note: Notes contain special information that warrants being set off from the body text as shown here.*

---

---

## **Static Discharge Protection**

---



Caution - Electronic components can be damaged by static electricity discharge.

Always observe the following precautions before removing, installing or handling any electronic components within the Inspection System:

- Wear an anti-static wristband which is grounded to the Inspection System.
- Stand on an anti-static, grounded floor mat, and lay circuit boards on the mat during any board replacement.
- Keep circuit boards in static shield bags when storing and transporting. Ensure the bag is sealed.

# Chapter 2

## EU Declarations of Conformity

### Declaration of Conformity - Intellispec System

<b>Declaration</b>	The listed product is in conformity with following Union harmonization legislation: Directive 2014/30/EU of the European Parliament and of the Council of 26 February 2014 on the harmonisation of the laws of the Member States relating to electromagnetic compatibility and with Directive 2014/35/EU of the European Parliament and of the Council of 26 February 2014 on the harmonisation of the laws of the Member States relating to the making available on the market of electrical equipment designed for use within certain voltage limits.  The Technical Documentation demonstrates the fulfillment of the essential requirements as set out in Annex I of the above Directive.
<b>Manufacturer</b>	Pressco Technology Inc. 29200 Aurora Road Cleveland, Ohio 44139-1847 USA This declaration of conformity is issued under the sole responsibility of the manufacturer.
<b>Product Name</b>	Intellispec Series V Inspection System
<b>Referenced harmonised standards to which conformity is declared:</b>	EN 61326-1:2013 Electrical equipment for measurement, control and laboratory use — EMC requirements — Part 1: General requirements EN 55011:2009 +A1:2010: Radiated / Conducted Emissions EN 61000-4-2:2009: ESD Immunity EN 61000-4-3:2006 + A1:2008 + A2:2010: Radiated RF Immunity EN 61000-4-4:2004 + A1:2010: EFT Burst Immunity EN 61000-4-5:2006: Surge Immunity EN 61000-4-6:2009: Conducted RF Immunity EN 61000-4-11:2004: Voltage Dips & Interruptions EN 61010-1:2010 Safety requirements for electrical equipment for measurement, control, and laboratory use - Part 1: General requirements
<b>Technical File</b>	EMR2932 & ES2932
<b>Place</b>	Pressco Technology Inc. 29200 Aurora Road Cleveland, Ohio 44139-1847 USA

Signed for and on behalf of Pressco Technology Inc., 29200 Aurora Road, Cleveland, OH USA 44139:

 VP, ENG OPERATIONS

Name, Position



Date

Signed: Fredrick F. Awig

Date: 22 August 2016

Name: **Fredrick F. Awig**

Title: **VP of Engineering & Operations**

Signed for and on behalf of Pressco Technology Inc.

## Declaration of Conformity - CSL System

<b>Declaration</b>	The listed product is in conformity with following Union harmonization legislation: Directive 2014/30/EU of the European Parliament and of the Council of 26 February 2014 on the harmonisation of the laws of the Member States relating to electromagnetic compatibility and with Directive 2014/35/EU of the European Parliament and of the Council of 26 February 2014 on the harmonisation of the laws of the Member States relating to the making available on the market of electrical equipment designed for use within certain voltage limits.  The Technical Documentation demonstrates the fulfillment of the essential requirements as set out in Annex I of the above Directive.
<b>Manufacturer</b>	Pressco Technology Inc. 29200 Aurora Road Cleveland, Ohio 44139-1847 USA This declaration of conformity is issued under the sole responsibility of the manufacturer.
<b>Product Name</b>	Compact Single Lane (CSL)
<b>Referenced harmonised standards to which conformity is declared:</b>	EN 61326-1:2013 Electrical equipment for measurement, control and laboratory use — EMC requirements — Part 1: General requirements EN 55011:2009 +A1:2010: Radiated / Conducted Emissions EN 61000-4-2:2009: ESD Immunity EN 61000-4-3:2006 + A1:2008 + A2:2010: Radiated RF Immunity EN 61000-4-4:2004 + A1:2010: EFT Burst Immunity EN 61000-4-5:2006: Surge Immunity EN 61000-4-6:2009: Conducted RF Immunity EN 61000-4-11:2004: Voltage Dips & Interruptions EN 61010-1:2010 Safety requirements for electrical equipment for measurement, control, and laboratory use - Part 1: General requirements
<b>Place</b>	Pressco Technology Inc. 29200 Aurora Road Cleveland, Ohio 44139-1847 USA

Signed for and on behalf of Pressco Technology Inc., 29200 Aurora Road, Cleveland, OH USA 44139:

 VP, ENG OPERATIONS

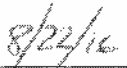

Name, Position

Date

Signed: Fredrick F. Awig

Date: 22 August 2016

Name: **Fredrick F. Awig**

Title: **VP of Engineering & Operations**

Signed for and on behalf of Pressco Technology Inc.

## Declaration of Conformity - FHCP3X-EZ System (MS)

<b>Declaration</b>	Pressco Technology, Inc. FHCP3X-EZ System is in conformity with Directive 2006/42/EC of The European Parliament and of the Council of 17 May 2006.
<b>Other Directives</b>	Directive 2014/30/EU of the European Parliament and of the Council of 26 February 2014 on the harmonization of the laws of Member States relating to electromagnetic compatibility.
<b>Manufacturer</b>	Pressco Technology Inc. 29200 Aurora Road Cleveland, Ohio 44139-1847 USA This declaration of conformity is issued under the sole responsibility of the manufacturer.
<b>Product Name</b>	FHCP3X-EZ System
<b>Electrical Diagram</b>	72999W and 72999E
<b>Standards Used (only major standards listed)</b>	EN60204-1 (2006): Safety of machinery – Electrical equipment of machine Part 1: General requirements EN14120 (2015): Safety of machinery – Guards – General requirements for the design and construction of fixed and movable guards EN ISO 13849-1 (2015): Safety of machinery - Safety-related parts of control systems - Part 1: General principles for design EN ISO 13855 (2010): Safety of machinery - Positioning of safeguards with respect to approach speeds of parts of the human body EN1037 (2008)+A1(2008): Safety of Machinery – Prevention of unexpected startup EN ISO 14119 (2013): Safety of machinery - Interlocking devices associated with guards - Principles for design and selection EN1837 (1999)+A1(2009): Safety of machinery - Integral lighting of machines EN13850 (2015): Safety of Machinery – Emergency stop equipment, functional aspects – Principles for design EN13857 (2008): Safety of Machinery – Safety distances to prevent danger zones from being reached by upper and lower limbs EN ISO 12100 (2010): Safety of machinery - General principles for design - Risk assessment and risk reduction
<b>Technical File</b>	MS4113
<b>Compiler of the Technical Files</b>	Safenet Ltd, Notified Body 1674 Denford Garage, Denford, Kettering, Northants., NN14 4EQ, U.K.
<b>Place</b>	Pressco Technology Inc. 29200 Aurora Road Cleveland, Ohio 44139-1847 USA

Signature of Manufacturer:

 VP, ENG. OPERATIONS

Name/Title/Signature

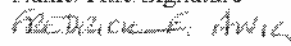

Place:

Pressco Technology Inc.  
29200 Aurora Road  
Cleveland, Ohio 44139-1847

25 May 2016.

Signed: Fredrick F. Awig

Date: 25 May 2016

Name: **Fredrick F. Awig**

Title: **VP of Engineering & Operations**

Signed for and on behalf of Pressco Technology Inc.

## Declaration of Conformity - FHCP3X-EZ System (EMC)

<b>Declaration</b>	Pressco Technology, Inc. FHCP3X-EZ System is in conformity with Directive 2014/30/EU of the European Parliament and of the Council of 26 February.
<b>Manufacturer</b>	Pressco Technology Inc. 29200 Aurora Road Cleveland, Ohio 44139-1847 USA This declaration of conformity is issued under the sole responsibility of the manufacturer.
<b>Product Name</b>	FHCP3X-EZ System
<b>Electrical Diagram</b>	72999W and 72999E
<b>Standards Used (only major standards listed)</b>	EN 61000-6-2 (2005) Electromagnetic compatibility – Part 6-2: Generic standards – Immunity for industrial environments EN 61000-6-4 (2007+A1:2011) Electromagnetic compatibility – Part 6-4: Generic standards – Emission standard for industrial environments BSEN 55011 (2009+A1:2010) Limits and methods of measurement of radio disturbance characteristics of industrial, scientific and medical (ISM) radio-frequency equipment
<b>Technical File</b>	EMC4113
<b>Competent Body</b>	Hursley EMC Services, Ltd. Notified Body of the U.K. 1890 Trafalgar House, Trafalgar Close Chandlers Ford, Eastleigh, Hampshire SO53 4BW, Great Britain
<b>Assessment Certificate Number</b>	14R538, Dated: March 18, 2015
<b>Means of Conformity</b>	The product is in conformity with Directive 2014/30/EU based on test results referencing harmonized standards and the use of a Technical File in accordance with Article 7 of the Directive.
<b>Place</b>	Pressco Technology Inc. 29200 Aurora Road Cleveland, Ohio 44139-1847 USA

Signature of Manufacturer:

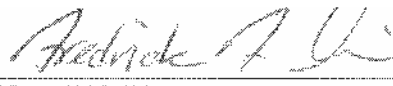
 VP, ENG & OPERATIONS  
Name/Title/Signature

Place:

Pressco Technology Inc.  
29200 Aurora Road  
Cleveland, Ohio 44139-1847

25 May 2016

Signed: Fredrick F. Awig

Date: 25 May 2016

Name: **Fredrick F. Awig**

Title: **VP of Engineering & Operations**

Signed for and on behalf of Pressco Technology Inc.

## Declaration of Conformity - Cluster Box

<b>Declaration</b>	The listed product is in conformity with following Union harmonization legislation: Directive 2014/30/EU of the European Parliament and of the Council of 26 February 2014 on the harmonisation of the laws of the Member States relating to electromagnetic compatibility and with Directive 2014/35/EU of the European Parliament and of the Council of 26 February 2014 on the harmonisation of the laws of the Member States relating to the making available on the market of electrical equipment designed for use within certain voltage limits.  The Technical Documentation demonstrates the fulfillment of the essential requirements as set out in Annex I of the above Directive.
<b>Manufacturer</b>	Pressco Technology Inc. 29200 Aurora Road Cleveland, Ohio 44139-1847 USA This declaration of conformity is issued under the sole responsibility of the manufacturer.
<b>Product Name</b>	Cluster Box
<b>Referenced harmonised standards to which conformity is declared:</b>	EN 61326-1:2013 Electrical equipment for measurement, control and laboratory use — EMC requirements — Part 1: General requirements EN 55011:2009 +A1:2010: Radiated / Conducted Emissions EN 61000-4-2:2009: ESD Immunity EN 61000-4-3:2006 + A1:2008 + A2:2010: Radiated RF Immunity EN 61000-4-4:2004 + A1:2010: EFT Burst Immunity EN 61000-4-5:2006: Surge Immunity EN 61000-4-6:2009: Conducted RF Immunity EN 61000-4-11:2004: Voltage Dips & Interruptions EN 61010-1:2010 Safety requirements for electrical equipment for measurement, control, and laboratory use - Part 1: General requirements
<b>Place</b>	Pressco Technology Inc. 29200 Aurora Road Cleveland, Ohio 44139-1847 USA

Signed for and on behalf of Pressco Technology Inc., 29200 Aurora Road, Cleveland, OH USA 44139:

 VP, ENG OPERATIONS



Name, Position

Date

Signed: Fredrick F. Awig

Date: 22 August 2016

Name: **Fredrick F. Awig**

Title: **VP of Engineering & Operations**

Signed for and on behalf of Pressco Technology Inc.

## Declaration of Conformity - Embedded Cluster Box

<b>Declaration</b>	The listed product is in conformity with following Union harmonization legislation: Directive 2014/30/EU of the European Parliament and of the Council of 26 February 2014 on the harmonisation of the laws of the Member States relating to electromagnetic compatibility and with Directive 2014/35/EU of the European Parliament and of the Council of 26 February 2014 on the harmonisation of the laws of the Member States relating to the making available on the market of electrical equipment designed for use within certain voltage limits.  The Technical Documentation demonstrates the fulfillment of the essential requirements as set out in Annex I of the above Directive.
<b>Manufacturer</b>	Pressco Technology Inc. 29200 Aurora Road Cleveland, Ohio 44139-1847 USA This declaration of conformity is issued under the sole responsibility of the manufacturer.
<b>Product Name</b>	Embedded Cluster Box
<b>Referenced harmonised standards to which conformity is declared:</b>	EN 61326-1:2013 Electrical equipment for measurement, control and laboratory use — EMC requirements — Part 1: General requirements EN 55011:2009 +A1:2010: Radiated / Conducted Emissions EN 61000-4-2:2009: ESD Immunity EN 61000-4-3:2006 + A1:2008 + A2:2010: Radiated RF Immunity EN 61000-4-4:2004 + A1:2010: EFT Burst Immunity EN 61000-4-5:2006: Surge Immunity EN 61000-4-6:2009: Conducted RF Immunity EN 61000-4-11:2004: Voltage Dips & Interruptions EN 61010-1:2010 Safety requirements for electrical equipment for measurement, control, and laboratory use - Part 1: General requirements
<b>Place</b>	Pressco Technology Inc. 29200 Aurora Road Cleveland, Ohio 44139-1847 USA

Signed for and on behalf of Pressco Technology Inc., 29200 Aurora Road, Cleveland, OH USA 44139:

 VP, ENG OPERATIONS

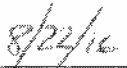

Name, Position

Date

Signed: Fredrick F. Awig

Date: 22 August 2016

Name: **Fredrick F. Awig**

Title: **VP of Engineering & Operations**

Signed for and on behalf of Pressco Technology Inc.

## Declaration of Conformity - CPX Inspection Module

<b>Declaration</b>	The listed product is in conformity with following Union harmonization legislation: Directive 2014/30/EU of the European Parliament and of the Council of 26 February 2014 on the harmonisation of the laws of the Member States relating to electromagnetic compatibility and with Directive 2014/35/EU of the European Parliament and of the Council of 26 February 2014 on the harmonisation of the laws of the Member States relating to the making available on the market of electrical equipment designed for use within certain voltage limits.  The Technical Documentation demonstrates the fulfillment of the essential requirements as set out in Annex I of the above Directive.
<b>Manufacturer</b>	Pressco Technology Inc. 29200 Aurora Road Cleveland, Ohio 44139-1847 USA This declaration of conformity is issued under the sole responsibility of the manufacturer.
<b>Product Name</b>	CPX Inspection Module
<b>Referenced harmonised standards to which conformity is declared:</b>	EN 61326-1:2013 Electrical equipment for measurement, control and laboratory use — EMC requirements — Part 1: General requirements EN 55011:2009 +A1:2010: Radiated / Conducted Emissions EN 61000-4-2:2009: ESD Immunity EN 61000-4-3:2006 + A1:2008 + A2:2010: Radiated RF Immunity EN 61000-4-4:2004 + A1:2010: EFT Burst Immunity EN 61000-4-5:2006: Surge Immunity EN 61000-4-6:2009: Conducted RF Immunity EN 61000-4-11:2004: Voltage Dips & Interruptions EN 61010-1:2010 Safety requirements for electrical equipment for measurement, control, and laboratory use - Part 1: General requirements
<b>Place</b>	Pressco Technology Inc. 29200 Aurora Road Cleveland, Ohio 44139-1847 USA

Signed for and on behalf of Pressco Technology Inc., 29200 Aurora Road, Cleveland, OH USA 44139:

 VP, ENG OPERATIONS

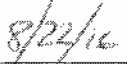

Name, Position

Date

Signed: Fredrick F. Awig

Date: 22 August 2016

Name: **Fredrick F. Awig**

Title: **VP of Engineering & Operations**

Signed for and on behalf of Pressco Technology Inc.

## Declaration of Conformity - Intellimass

<b>Declaration</b>	The listed product is in conformity with following Union harmonization legislation: Directive 2014/30/EU of the European Parliament and of the Council of 26 February 2014 on the harmonisation of the laws of the Member States relating to electromagnetic compatibility and with Directive 2014/35/EU of the European Parliament and of the Council of 26 February 2014 on the harmonisation of the laws of the Member States relating to the making available on the market of electrical equipment designed for use within certain voltage limits.  The Technical Documentation demonstrates the fulfillment of the essential requirements as set out in Annex I of the above Directive.
<b>Manufacturer</b>	Pressco Technology Inc. 29200 Aurora Road Cleveland, Ohio 44139-1847 USA This declaration of conformity is issued under the sole responsibility of the manufacturer.
<b>Product Name</b>	Intellimass
<b>Referenced harmonised standards to which conformity is declared:</b>	EN 61326-1:2013 Electrical equipment for measurement, control and laboratory use — EMC requirements — Part 1: General requirements EN 55011:2009 +A1:2010: Radiated / Conducted Emissions EN 61000-4-2:2009: ESD Immunity EN 61000-4-3:2006 + A1:2008 + A2:2010: Radiated RF Immunity EN 61000-4-4:2004 + A1:2010: EFT Burst Immunity EN 61000-4-5:2006: Surge Immunity EN 61000-4-6:2009: Conducted RF Immunity EN 61000-4-11:2004: Voltage Dips & Interruptions EN 61010-1:2010 Safety requirements for electrical equipment for measurement, control, and laboratory use - Part 1: General requirements
<b>Place</b>	Pressco Technology Inc. 29200 Aurora Road Cleveland, Ohio 44139-1847 USA

Signed for and on behalf of Pressco Technology Inc., 29200 Aurora Road, Cleveland, OH USA 44139:

 VP, ENG OPERATIONS

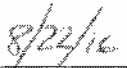

Name, Position

Date

Signed: Fredrick F. Awig

Date: 22 August 2016

Name: **Fredrick F. Awig**

Title: **VP of Engineering & Operations**

Signed for and on behalf of Pressco Technology Inc.

# Chapter 3

## Safety Information

This section contains operator safety information that must be read before operating or servicing the system.



Warning - Do not, under any circumstances, tamper with sealed machine parts or devices. This could result in the removal of protections that might create potentially hazardous conditions.



Warning - This product contains no operator serviceable parts. Refer servicing to qualified personnel. To prevent electrical shock do not open cabinet doors whilst power is connected.

## Health Warnings - Photosensitive Epilepsy



**WARNING: PHOTSENSITIVE EPILEPSY/ SEIZURES**

A small percentage of individuals may experience epileptic symptoms or seizures when exposed to certain patterns or flashing lights. Exposure to the flashing lights in vision inspection systems may also trigger epileptic symptoms or seizures in these individuals. These flashing lights may trigger epileptic symptoms or seizures in persons who have no history of epileptic symptoms or seizures. If you, or anyone in your family has an epileptic condition or has had seizures of any kind, consult your physician before operating this machinery.

**IMMEDIATELY DISCONTINUE** use and consult your physician if you experience any of the following symptoms while operating this machinery:

- Dizziness
- Altered vision
- Eye or muscle twitches
- Loss of awareness
- Disorientation
- Seizures
- Any involuntary movement or convulsion

**Epileptic symptom or seizure triggers vary from person to person. Some common triggers are:**







- Flashing lights used for vision inspection systems or fire alarms
- Certain video games or TV broadcasts containing rapid flashes or alternating patterns of different colors
- Bright, contrasting patterns such as white bars against a black background
- Flashing white light followed by darkness
- Stimulating images that take up your complete field of vision, such as being very close to a TV screen or computer monitor
- Certain colors, such as red and blue

**If you encounter something that might trigger epileptic symptoms or seizures without warning:**

- Do not close your eyes (this could cause a flicker effect)
- Do not look directly at the flashing lights or trigger source
- Do cover one eye with the palm of your hand immediately
- Do turn away from the flashing lights or trigger source

## Symbols

The following symbols are used on or near the Intellispec system. Be aware of potential risk hazards.

	CAUTION Risk of danger. Refer to accompanying user documentation before use.
	WARNING Risk of electric shock
	On (supply)
	Off (supply)
	Alternating current
	Protective conductor terminal

## Marking

The following illustration shows an example label that you will find on the Intellispec system components.

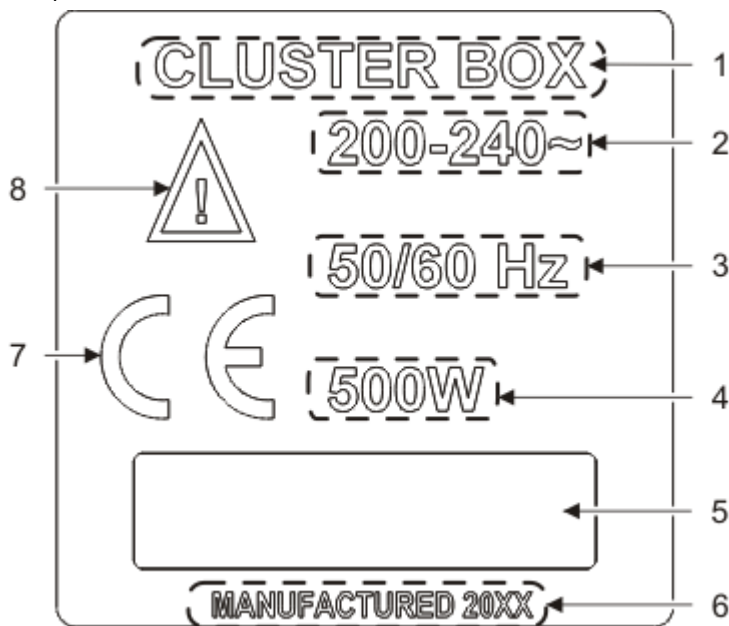

- 1) Name of component. NOTE: Chromapulse model is listed on the front panel of the module. See example below.
- 2) Voltage range in Volts AC
- 3) Frequency range in Hertz (Hz)
- 4) Maximum rated power in watts (W) with all accessories or plug-in modules connected
- 5) Serial number is listed in this box
- 6) Year of manufacture
- 7) Component certification
- 8) Risk of danger. Refer to accompanying documentation before use.

An example of a Chromapulse module label with the model number is shown below.

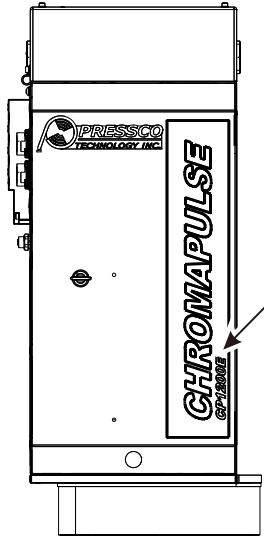

---

## Warning Devices

The Intellispec vision inspection system has warning devices that indicate system failure or report excessive defects or warnings for your production line.

### Alarms

User-programmable alarms allow you to set the duration of the lights in the optional light tree and the horn if certain criteria are met.

In addition to the light tree, an alarm button is displayed on screen when certain criteria are met. You can click the alarm button to clear the alarm and see more detailed information about the alarm condition.



### Light Tree

The optional light tree may be mounted on or near an inspection module, or near a cluster box (if applicable). The optional horn, mounted with the light tree provides an audible warning.

For more information, refer to Light tree status.



Light Tree (optional)

- Red (Alarm)
- Amber (Warning)
- Green (Online)
- Blue (Power)

---

## Residual Risk

The Pressco system has been designed to minimize any danger of personal injury. However, the system uses rejection devices to remove defective product from the production stream. Also, the electronics cabinets contain risk of shock if they are opened.

Observe the following safety warnings when operating the system or working near it:



Warning - Potential for projectiles to strike persons and cause injury. Keep clear of reject devices.



Warning - Sensitive electronics and High Voltages may be exposed. Keep Processor Cabinet/ Electrical Control Box door closed.

---

## Intended Use

**Type of Process:** The Pressco system is intended to monitor container and other special manufacturing processes and identify non-conforming product.

**Intended Use:** The Pressco system is designed and constructed for use in an indoor industrial environment, always sheltered from the weather.

**Space Required:** The Pressco system and accompanying sensors must be installed in a place that will enable safe and easy installation, size changeover, user operation, and maintenance procedures.

---

## Prohibited Use





Warning - If this instrument is not used as specified, the protection provided by the equipment could be impaired. This instrument must only be used in a normal condition (in which all means of protection are intact).



Important - The Pressco system should NOT be used for any purpose other than specifically indicated in the section titled **Intended Use** (on page 20).

The following uses are **not** intended:

-  Use in an explosive environment
-  Use in a flammable environment
-  Use in a damp, moist, or wet environment, except where specifically indicated





---

## Personal Protective Equipment



Important - Always follow the safety requirements of your plant in addition to the recommendations below.





We recommend, at minimum, use of the following Personal Protective Equipment (PPE):

	Protective clothing
	Protective gloves
	Protective ear plugs or headphones
	Protective eye wear
	Protective foot wear







## Personnel Safety

The following rules are recommended to ensure the safety of personnel in charge of machine operation and maintenance.

### During machine operation:

	Only one operator is needed to operate the machine. All others must keep at a safe distance.
	Operators must be familiar with all machinery connected to the Pressco equipment and know how to use emergency stop devices. Note: the emergency stop devices may not be connected directly to the Pressco equipment, but it is important to know how to use them.
	Before putting the Pressco system online, the operator must ensure that all safety devices used with all connected machinery are in place and operational.
	The operator must maintain maximum focus on his work and be alert throughout his shift. If this is not the case, immediately inform the shift supervisor.

### When carrying out maintenance or repair work:

	Disconnect master switch. For switch locations, refer to the <b>Power Up</b> (on page 59) and Power Down section.
	Before starting the machine, ensure that no person is close to the machine.
	If maintenance or repair requires the disconnection or removal of safety or protection systems, this operation must be supervised by authorized personnel who must ensure the prevention of personal injury or damage to the machine. All machine movements must be performed with limited speed and limited movements.
	Maintenance or repair work on electrical components must be carried out exclusively by authorized, trained personnel. When running tests with power connected, you must strictly comply with the rules provided.
	Personnel working on higher parts of a machine must wear a harness and hook it on to the structure and must always move with extreme caution.
	Never perform lubrication or maintenance procedures on mechanical parts with the machine running.

 For your safety, **do not:**

- Open safety guards during machine operation
- Perform maintenance and repair while the system is running
- Lean on the machine
- Sit on the machine components
- Use the machine for purposes other than those listed in this manual
- Modify parts of the machine
- Allow unqualified personnel to operate or perform maintenance procedures on the machine

## Lifting heavy objects



Caution - Some components are heavy. Take proper precautions to prevent personal injury or damage to equipment. If you are not capable of lifting the object alone, ask a capable person to help lift the object, or use a mechanical lifting device

The components do not have handles to lift the equipment. Be sure to:

- Lift equipment from the bottom - do not use wires, brackets, nor other protrusions
- Keep fingers away from sensor lenses to keep the equipment clean
- Proceed slowly

➤ **To safely lift equipment:**



Caution - Do not twist your body when moving the load. Instead take small steps with your feet turning until you are in the correct position.

1. Stand close to the load and center yourself over it with your feet shoulder width apart.
2. Tighten your abdominal muscles.
3. Keeping your back straight, bend your knees and squat down to the floor.
4. Get a good grasp on the load with both hands.
5. Keeping the load close to your body, use your leg muscles to stand up lifting the load off the floor.

- Your back should remain straight throughout lifting, using only the muscles in the legs to lift the load.
6. To place the load in the appropriate spot, bend at the knees using only your leg muscles to lower the load.

---

## Authorized Users

Trained machine operators, mechanic and electrical maintenance staff, and plant managers are considered authorized users of the Pressco system. These users should carefully read the information contained in this manual. The plant manager must ensure that the safety recommendations included in this manual are observed.



Warning - Allowing workers who are unfamiliar with the production process to operate the Pressco system could result in hazard risk.

If you are unclear about any part of this manual, **contact Pressco Technical Support** (on page 2).



Important - No worker should ever operate the system outside of his/ her own area of competence and responsibility.

### Proper Operation:

Only one worker is to operate the system at any given time. The correct position for the operator is in front of the user interface monitor or control enclosure (if applicable).

### Repairs:

Any repair on the system shall be carried out exclusively by Pressco Technology Inc. service personnel or by other service expressly authorized by Pressco Technology Inc.

---

## Spare Parts Usage

The following restrictions apply to replacing parts:



Warning - Using spare parts that are not designed to Pressco's specifications can compromise the safety and effectiveness of the Pressco system.

- The use of parts that are not within Pressco's design specifications is prohibited. This prohibition applies in particular when the parts involved contain or are connected with safety devices.
- Before resuming production, make sure all safety devices are in working order.

Pressco Technology Inc. shall not be liable in any way if any of the above-described directions are not complied with.

To obtain a spare parts list, contact the customer service department at Pressco. **How to Contact Pressco** (on page 2).

Pressco's technicians are available to help customers, in their own plant, to solve any problem that might arise during use and maintenance of the system.



# Chapter 4

## System Specifications

This instrument has been designed and tested in accordance with Publication EN61010-1 (2010) Safety Requirements for Electrical Equipment for Measurement, Control and Laboratory Use and has been supplied in a safe condition. The instruction documentation contains information and warnings which must be followed by the user to ensure safe operation and to maintain the instrument in a safe condition.

For dimensions and other specifications for other Intellispec systems, refer to:

- FHCP 3X systems: "Hardware Guide [FHCP 3X EZ]"
- Compact Single Lane systems: "Hardware Guide [CSL+]"

---

## Environmental conditions

The Intellispec Series V system is designed to be safe in the following environmental conditions:

- ❖ *Note: Please consult Pressco Technology Inc. (on page 2) if your environmental conditions are outside of those listed.*
- 

Condition	Specifications
Indoor/ outdoor use	Indoor use only
Altitude	Up to 2000 meters
Operating Temperature	5 °C to 50 °C
Storage Temperature	0 °C to 70 °C
Humidity	Maximum relative humidity 80 % for temperatures up to 31 °C decreasing linearly to 50 % relative humidity at 50 °C
Mains supply	Voltage fluctuations up to $\pm 10\%$ of the nominal voltage
Overvoltage protection rating	Transient overvoltage typically present on MAINS supply NOTE: the normal level of transient overvoltages is impulse withstand (overvoltage) category II of IEC 60364-4-443.
Rated pollution degree	This instrument is designed for use in Installation Category II and Pollution Degree 1 as per EN61010-1 and EN60664 respectively.



Warning - This is a Class A product. In a domestic environment this product may cause radio interference in which case the user may be required to take adequate measures.

## Sound Pressure Level

The horn on the optional *light tree* (on page 19) has a maximum 105dB level at 1 meter distance in front of the horn. Use proper hearing protection as specified by your plant safety instructions.

---

## Specifications

The following sections contain electrical specifications and measurements for components of the Intellispec Series V system. Your system contains only the components necessary for your application.

## User Interface

### *User Interface Electrical Specifications*

<b>Standard User Interface - No UPS included</b>	
Voltage Range	100-240VAC
Frequency	50/60Hz
Current	5A @ 120VAC, 100% Load

<b>User Interface with Optional 750VA UPS, 120VAC Nominal</b>	
Voltage Range	100-132VAC
Frequency	50/60Hz
Current	6.3A @ 120VAC, 100% Load

<b>User Interface with Optional 1KVA UPS, 230VAC Nominal</b>	
Voltage Range	200-240VAC
Frequency	50/60Hz
Current	4.3A @ 230VAC, 100% Load

## User Interface measurements

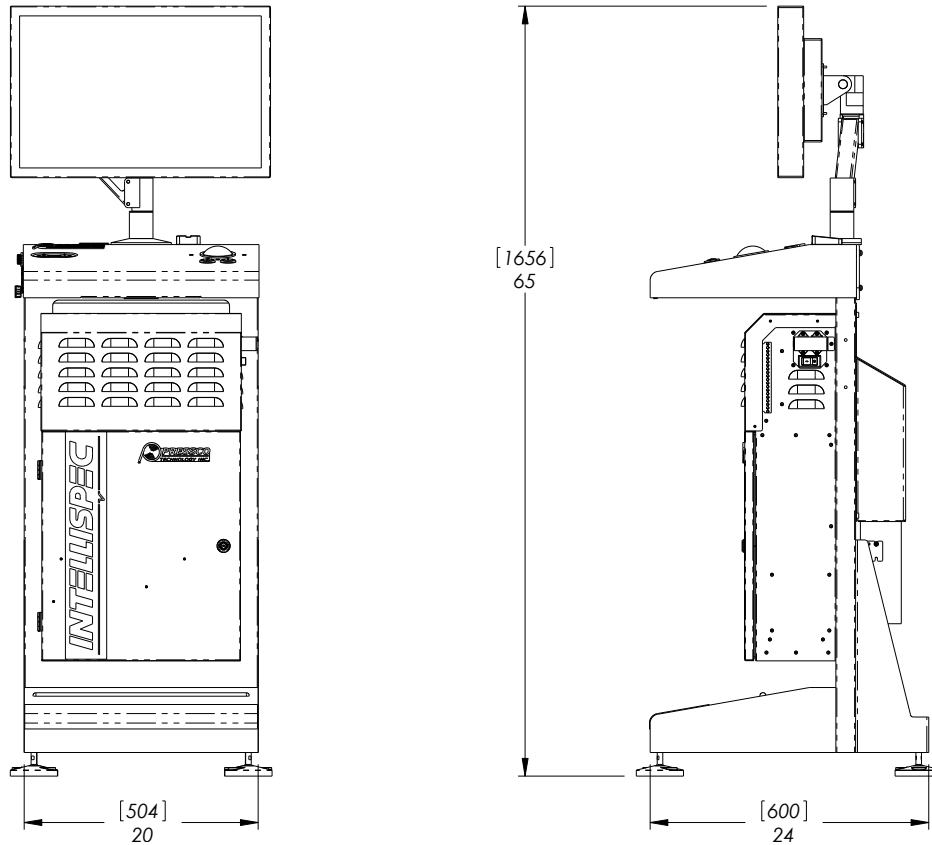

Measurement	Value
Weight (total user interface)	79.7 Kg [177 lb]
Weight (stand with monitor arm and all attached components)	31 Kg [68 lb]
Weight (computer)	25 Kg [55 lb]
Weight (Monitor)	11.3 Kg max [25 lb]
Weight (UPS)	12.7 Kg [28 lb]
Height	1656 mm [65 in]
Width	504 mm [20 in]
Depth	600 mm [24 in]

## Integrated Tunnel Electrical Specifications

The following are electrical specifications for the integrated tunnel (an inspection module that contains cameras and part tracking in one unit, such as the CP/ EV series tunnels).

<b>Standard - No UPS</b>	
Voltage Range	100-240VAC
Frequency	50/60Hz
Current	6.2A @ 120VAC, 100% Load

<b>Optional 500VA UPS, 120VAC Nominal</b>	
Voltage Range	100-132VAC
Frequency	50/60Hz
Current	4.1 @ 120VAC, 100% Load

<b>Optional 500VA UPS, 230VAC Nominal</b>	
Voltage Range	200-240VAC
Frequency	50/60Hz
Current	2.2A @ 230VAC, 100% Load

***CP/EV module measurements***

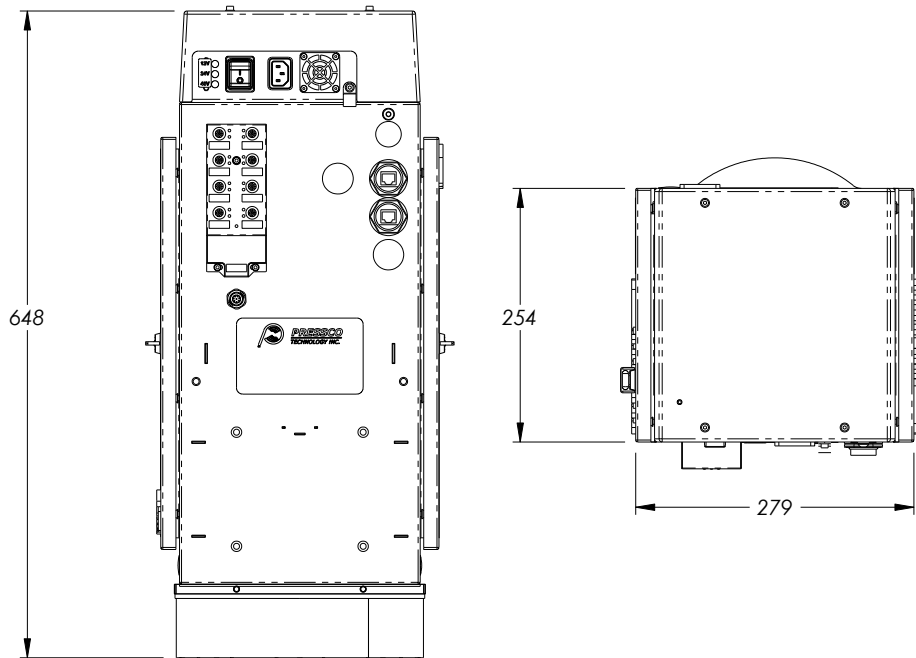

<b>Measurement</b>	<b>Value</b>
Weight	16.4 Kg [36 lb]
Height	648 mm
Width	254 mm
Depth	279 mm

❖ *Note: measurements do not include connectors*



Caution - This object is heavy. Review the section on *lifting heavy objects* (on page 22) before moving this object.

## Base, Neck, and Seal inspection module weights

Measurement	Value
Weight (total base, neck, seal mast and modules)	44 Kg [98 lb]
Weight (base camera module)	2.3 Kg [5 lb]
Weight (neck camera module)	2.7 Kg [6 lb]
Weight (seal camera module with light array)	2.7 Kg [6 lb]
Weight (BNS lower unit - lighting arrays)	8.2 Kg [18 lb]
Weight (BNS mast)	34.6 Kg [77 lb]

### Base camera module dimensions Series V

❖ Note: measurements do not include connectors

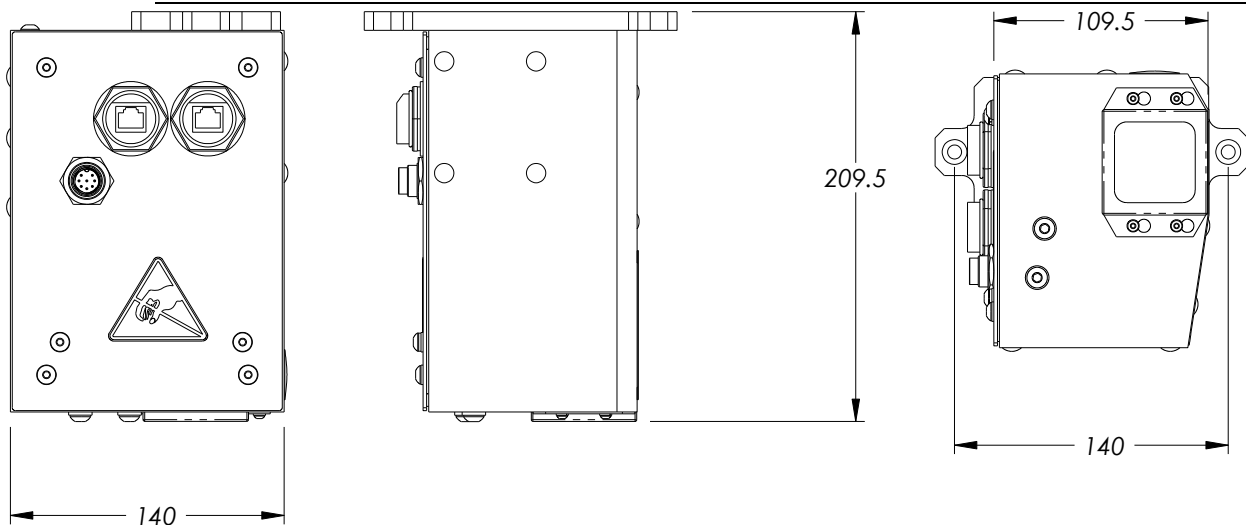

Position module 5 to 15 mm over seal surface.

Measurement	Value
Height (base camera module)	209.5 mm
Width (base camera module)	140 mm
Depth (base camera module)	140 mm

## Neck/ Sidewall camera dimensions Series V

❖ Note: measurements do not include connectors

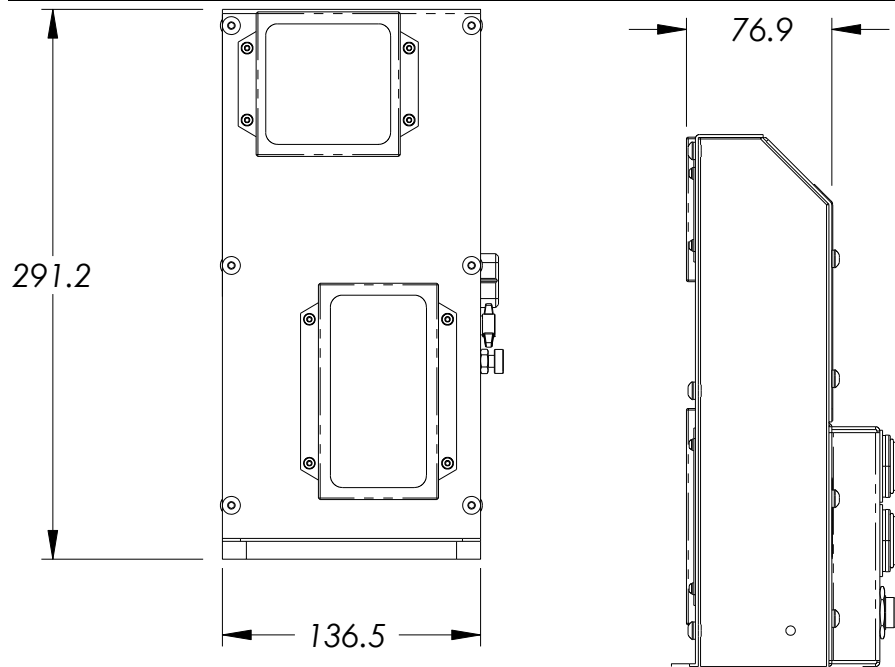

Measurements are shown in millimeters.

## Base/Neck mast dimensions Series V

The base/neck mast holds the lighting arrays for the base and neck inspection modules.

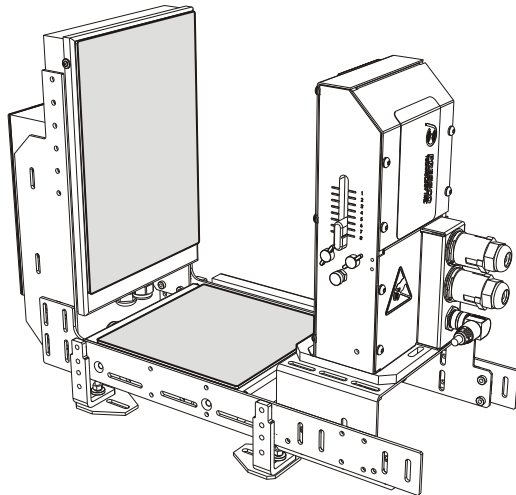

❖ Note: measurements do not include connectors



Caution - This object is heavy. Review the section on **lifting heavy objects** (on page 22) before moving this object.

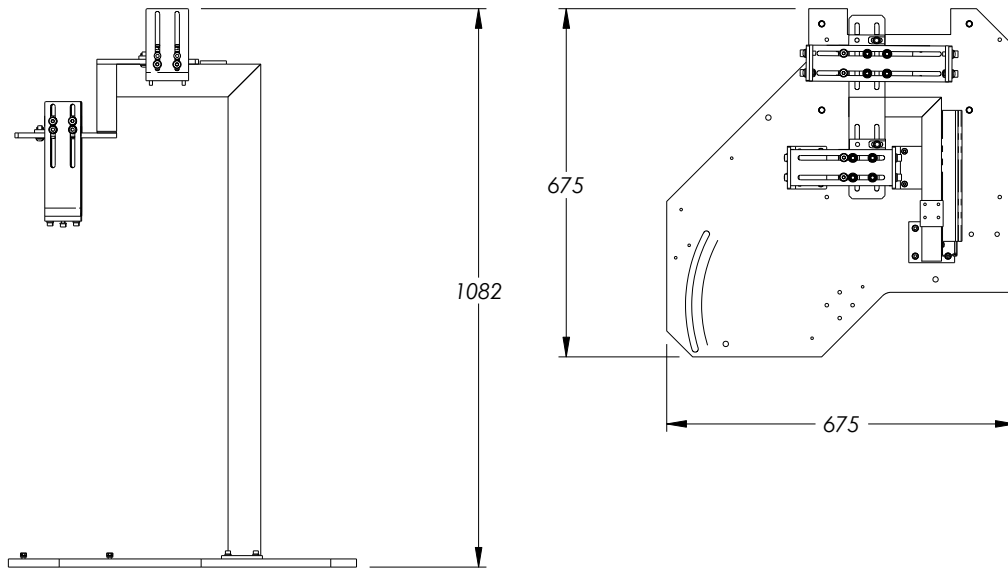

Measurements are shown in millimeters.

### **Seal Surface Inspection module dimensions Series V**

❖ Note: measurements do not include connectors

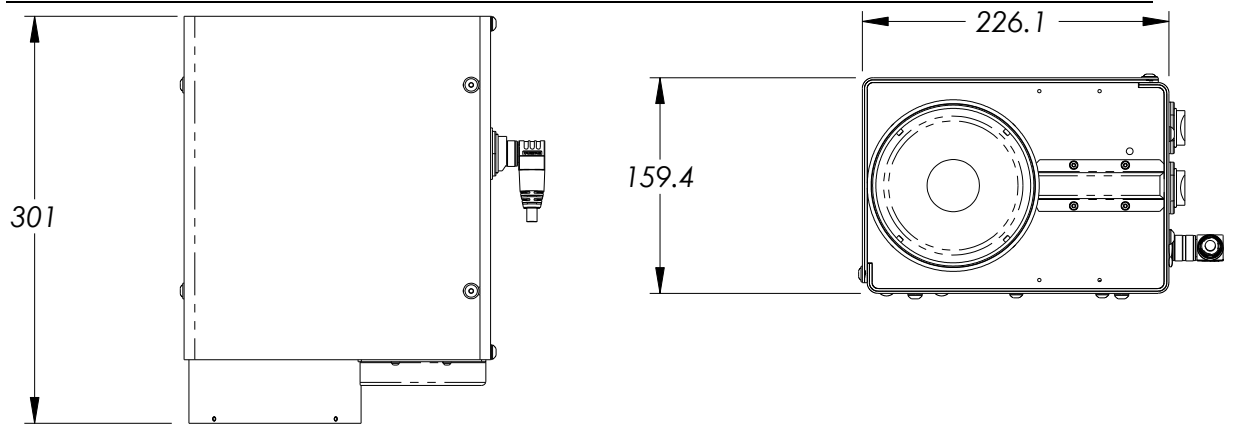

- For finish  $\varnothing$  less than 35 mm, position 112 mm above grippers
- For finish  $\varnothing$  greater than 35 mm, position 175 mm above grippers

Measurement	Value
Height	301 mm
Width	226.1 mm
Depth	159.4 mm

## Preform Seal Endcap Inspection module dimensions

❖ Note: measurements do not include connectors

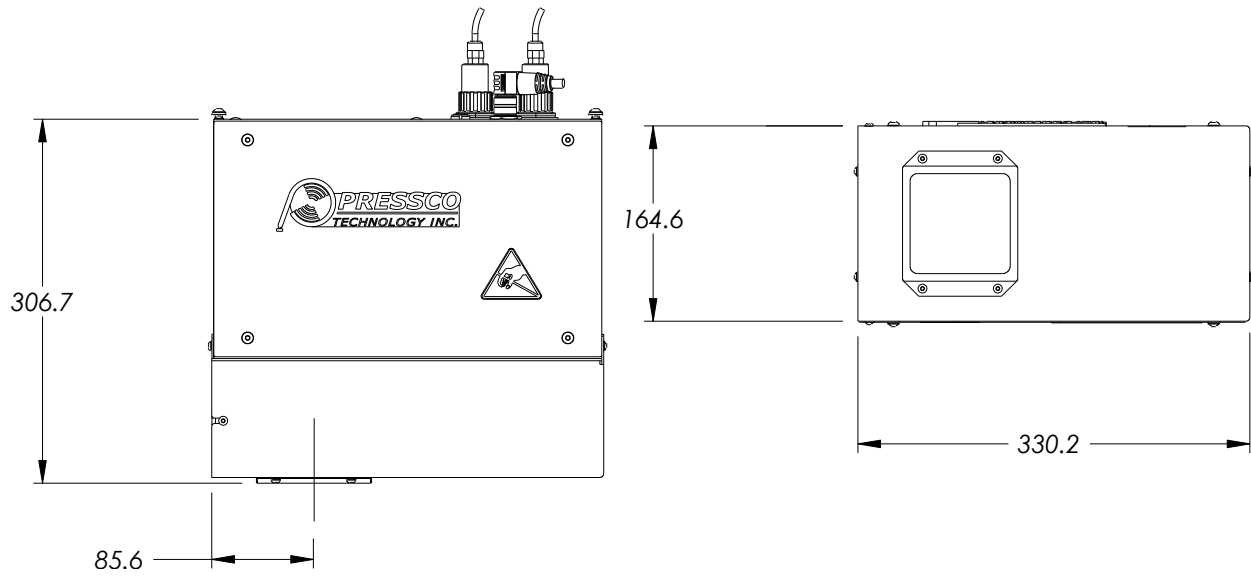

Measurement	Value
Height	306.7 mm
Width	330.2 mm
Depth	164.6 mm
Distance from edge to center of preform	85.6 mm

Position the module from reference "A" to 25 mm above the seal surface of the preform.

## Preform Sidewall Inspection module dimensions

❖ Note: measurements do not include connectors

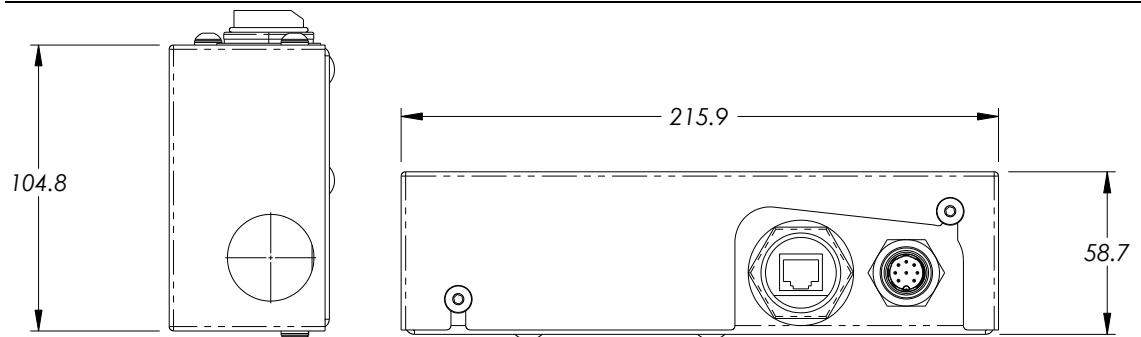

Measurements are shown in millimeters.

## Cluster Box Series V

### Cluster Box Electrical Specifications



Caution - Before switching on this instrument, ensure the power supply voltage is in the specified range.

❖ *Note: the Cluster Box is not present in all systems. It is mainly used when sensors are installed within a blow molder or similar machinery.*

<b>500VA UPS, 120VAC Nominal</b>	
Voltage Range	100-132VAC
Frequency	50/60Hz
Current	4.2A @ 120VAC, 100% Load

<b>500VA UPS, 230VAC Nominal</b>	
Voltage Range	200-240VAC
Frequency	50/60Hz
Current	2.2A @ 230VAC, 100% Load

<b>1KVA Transformer, 400VAC</b>	
Voltage Range	380-420VAC
Frequency	50/60Hz
Current	2.5A @ 400VAC, 100% Load

### Classic Cluster Box measurements

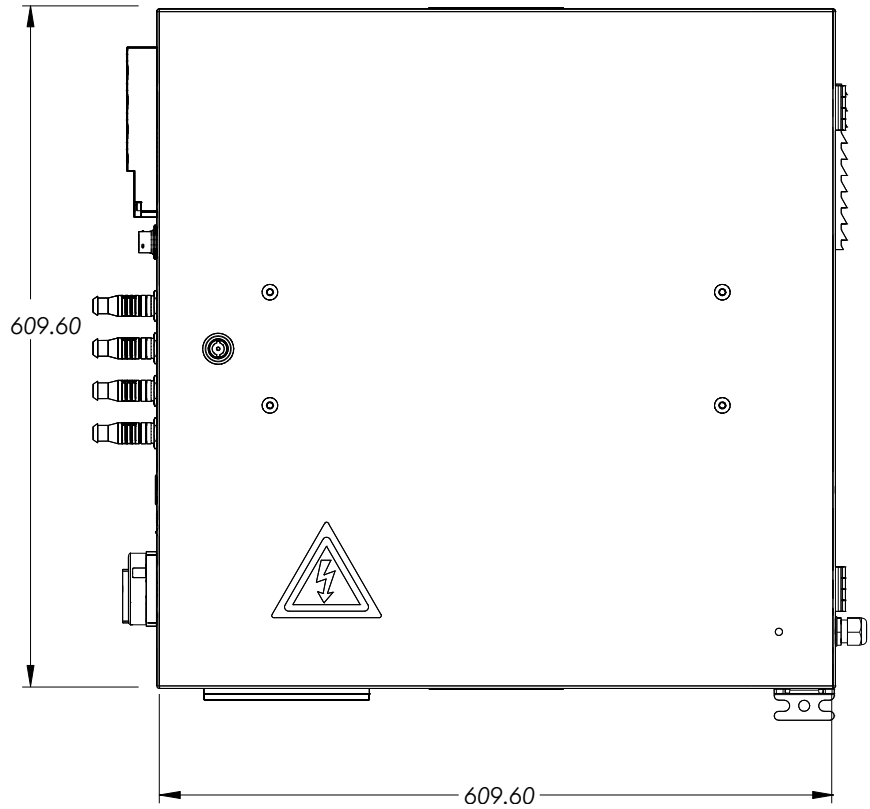
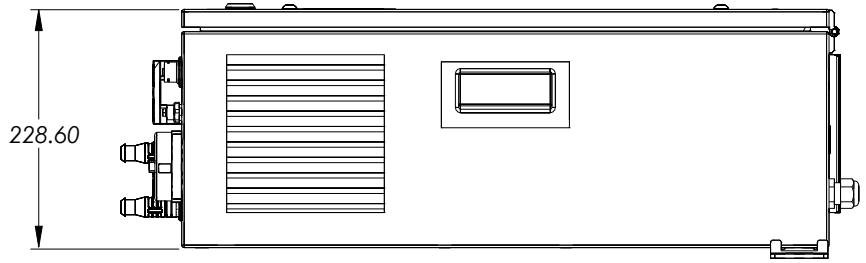

Measurement	Value
Weight	45 Kg [99 lb]
Height	609.60 mm [24 in]
Width	609.60 mm [24 in]
Depth	228.60 mm [9 in]

❖ Note: measurements do not include connectors or switches.



Caution - This object is heavy. Review the section on **lifting heavy objects** (on page 22) before moving this object.

## Embedded Cluster Box measurements

The following are the weight and dimensions of the 400V Embedded Cluster Box.

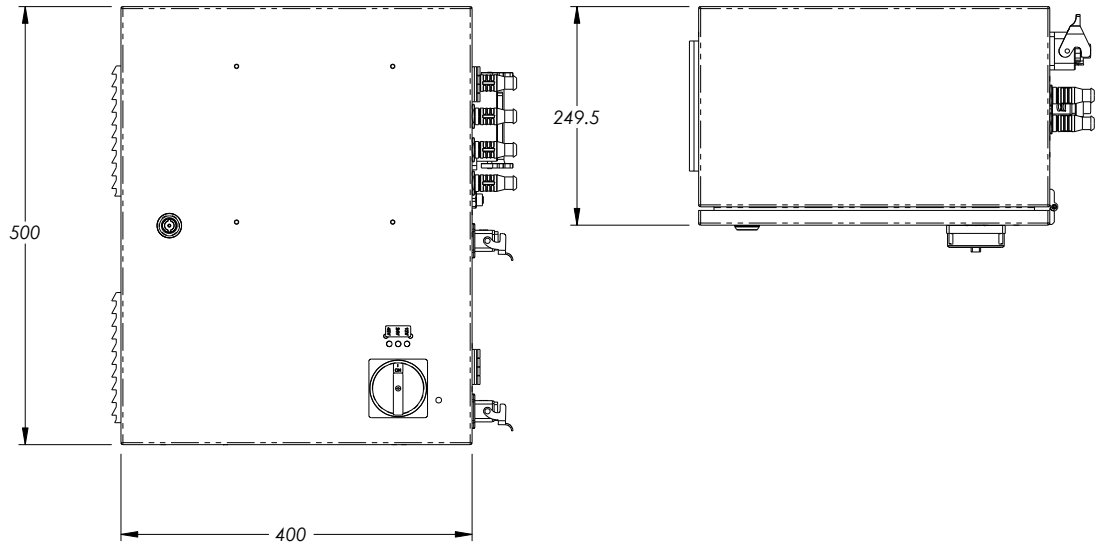

Measurement	Value
Weight	45 Kg [99 lb]
Height	500 mm [19.69 in]
Width	400 mm [15.75 in]
Depth	249.5 mm [9.82 in]

❖ Note: measurements do not include connectors or switches



Caution - This object is heavy. Review the section on **lifting heavy objects** (on page 22) before moving this object.

## Micro and Wash-Down Cluster Box measurements

The following are the weight and dimensions of the Micro or Wash-Down Cluster Box.

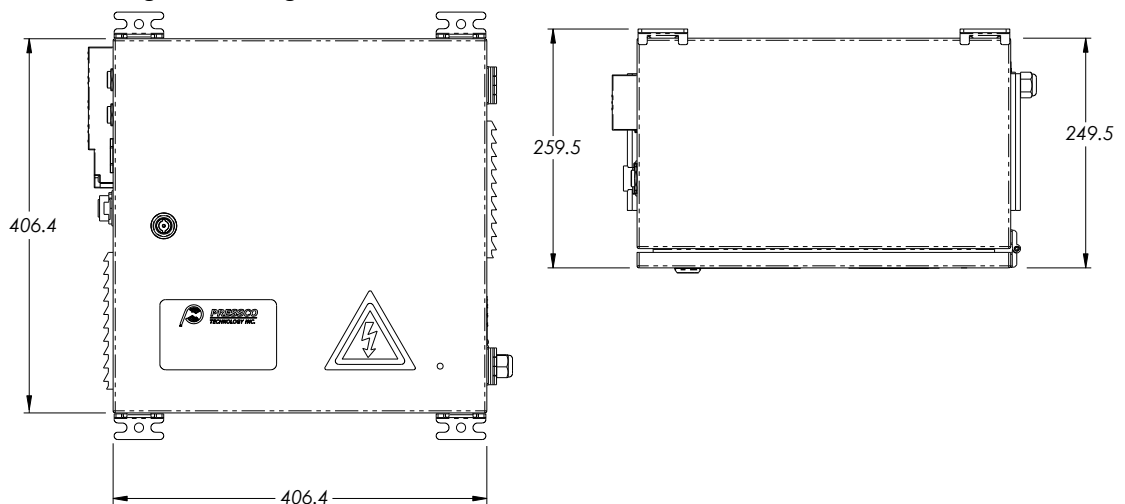

Measurement	Value
Weight	30.23 Kg [66.5 lb]
Height	406.40 mm [16 in]
Width	406.40 mm [16 in]
Depth	254 mm [10 in]

---

❖ *Note: measurements do not include connectors or switches.*

---



Caution - This object is heavy. Review the section on **lifting heavy objects** (on page 22) before moving this object.

# Chapter 5

## Installation and Wiring

### Shipping and Handling

Pressco Technology Inc. ships unassembled components in packing cases designed to protect the contents during handling and from exposure to weather.

Unless otherwise specified in the contract with the machine order, the Customer shall supply Pressco Technology Inc. with the means and equipment necessary for the unloading, lifting, and handling of machine parts. Pressco Technology Inc. deems it important to have one of their technicians supervise the process of unloading, handling, and lifting the machine. The technician can give useful advice as to the logical sequence in which the components should be unpacked and positioned for ease of assembly.



Warning - Only qualified personnel must be involved in the operation of unloading, handling, and lifting the machine. Pressco Technology Inc. shall not be liable for damage to components and/or personal injury resulting from the involvement of unauthorized personnel and/or failure to comply with the directions provided in this manual in relation to lifting and transport.



Important - The site supervisor will be responsible for ensuring that all the various mounting phases are carried out safely and in compliance with current regulations.

After the machine is delivered, check for any damage that might have occurred during shipping. In case of damage, contact **Pressco Technology Inc** (on page 2).

In handling the machine, always keep it close to the ground.



We recommend using a forklift truck with adequate capacity and forks to suit the weight to be lifted (machine plus packaging).

The dimensions and weight of a crate are listed below. Note that this is the maximum size and weight. The size and weight of the crate may be less depending on your configuration. You may receive multiple crates depending on your configuration.

<b>Size</b>	152.4 cm x 124.46 cm x 152.4 cm (60 x 49 x 60 inches)
<b>Weight</b>	453.592 kg (1000 lbs.)

### Recommendations prior to installation

Before the machine is installed, the Pressco installer, together with the Customer (or representative) shall check the following criteria in the environment where the machine is to be installed:

- Work required by contract for the installation of the machine has been carried out
- The plant layout drawing that describes where the machine will be installed is the final drawing agreed to by Pressco Technology Inc.
- The space and height required for installation are actually available
- Only the components included in the installation layout are present in the area where the machine is to be mounted. Ensure no machines or components have been added at a later stage that might hinder mounting or make it more difficult. Should this be the case, immediately contact Pressco's Project Engineering personnel to arrange a suitable solution to the problem.

We recommend the following prior to machine installation:

- Transport the machine in its packaging to the area where it will be installed to minimize possibility of damage
- Carefully remove the packaging material and check components for damage
- Check tightness of mechanical components, as they can loosen during transport
- Prepare the compressed air mains line. Before making final connections, ensure that the pipes are clean and free from any debris.

## System Block Diagram - BNS

The drawing below shows a basic block diagram for a typical BNS system with a cluster box and three sensors (camera modules). The drawing shows camera modules that contain only one camera each.

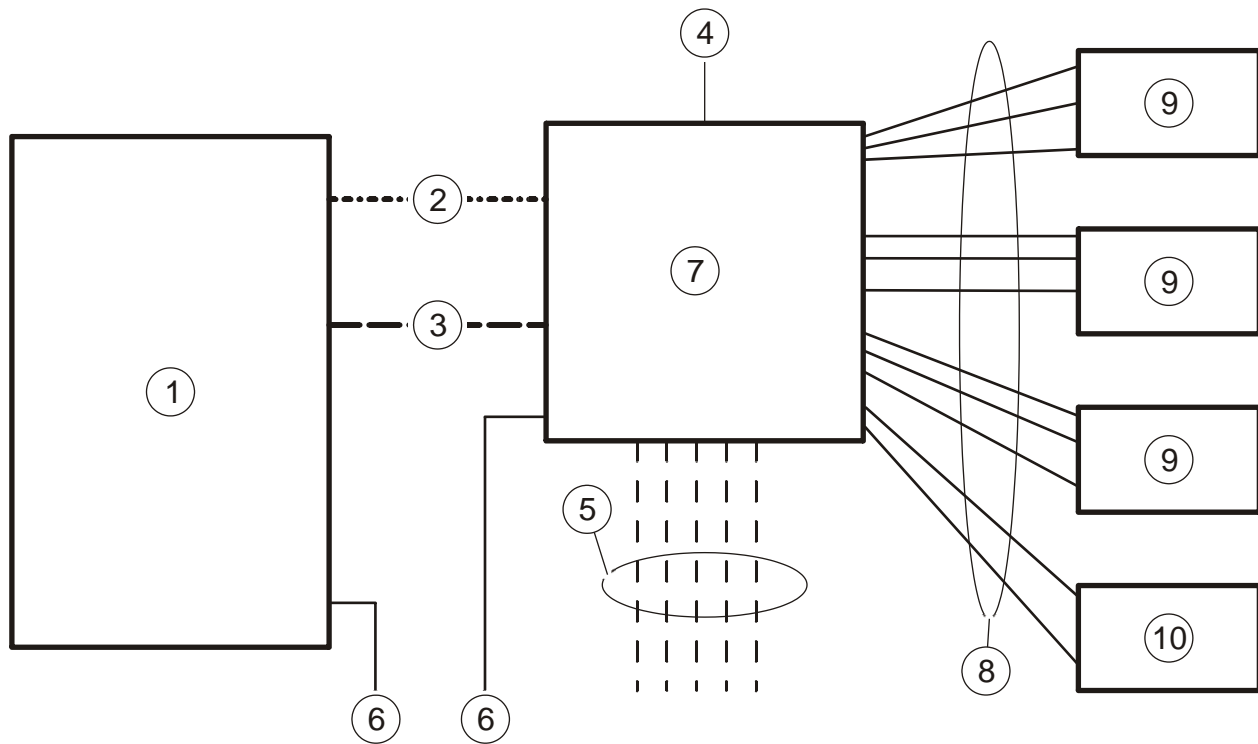

- 1) Vision Processor (PC, monitor, and UPS)
- 2) PDN (Pressco Data Network) ethernet green cable
- 3) Inspection sensor/ camera ethernet blue cable
- 4) Light tree (optional)
- 5) Sensor cables (for part present sensor, encoder, machine part, pocket detect, reject confirm) For details: *I/O connectors* (see "**Chromapulse module external connections**" on page 47, "**8 port I/O boxes**" on page 51)
- 6) AC power
- 7) Cluster box
- 8) PDN ethernet green cable, Inspection sensor/ camera ethernet blue cable, power and trigger cable (item 10 has only PDN cable and power and trigger cable)
- 9) Inspection sensor/ camera module (example: base, neck, seal surface)
- 10) Light array assembly (for base/neck cameras)

---

## System Block Diagram - Integrated Tunnel

Below is a basic block diagram for Series V Intellispec. This drawing shows the major components for the system. Your system will contain only the components required for your application. The numbered components are listed in the table below.

The drawing below shows a basic block diagram for a system with an integrated tunnel (with one camera).

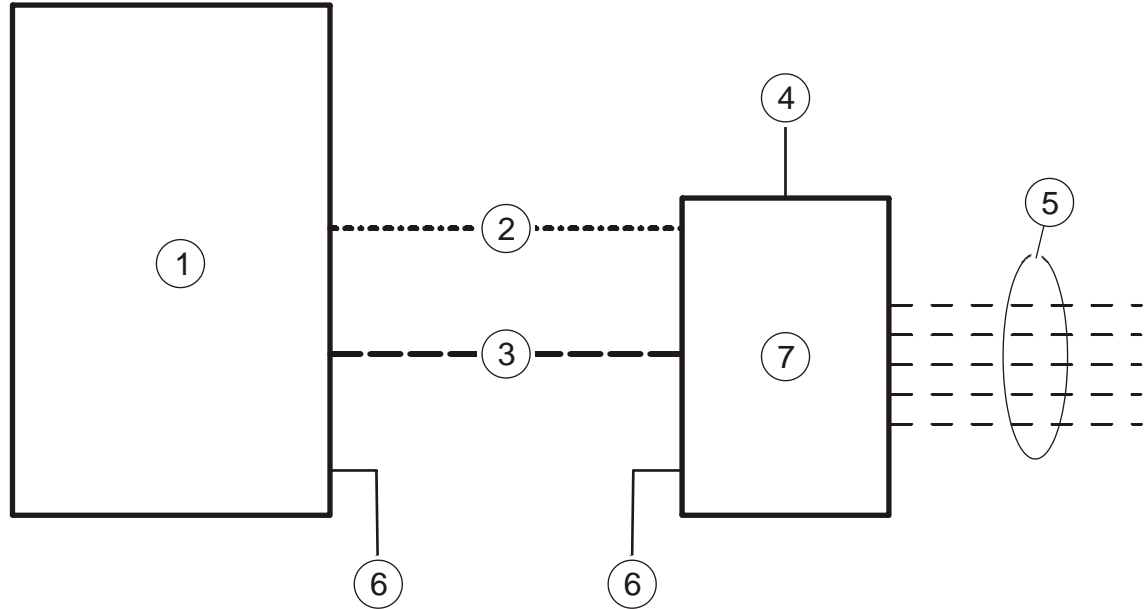

- 1) User Interface (PC, monitor, and UPS)
- 2) PDN (Pressco Data Network) ethernet green cable
- 3) Inspection sensor/ camera ethernet blue cable
- 4) Light tree (optional)
- 5) Sensor cables (for part present sensor, encoder, machine part, pocket detect, reject confirm) For details: *I/O connectors* (see "*Chromapulse module external connections*" on page 47, "*8 port I/O boxes*" on page 51)
- 6) AC power
- 7) Integrated tunnel (example: CP/EV inspection module)

---

## Assembly, location, and mounting requirements

### Utilities to be supplied by customer

The following utilities are required to operate the Pressco Intellispec system. Before making connection, make sure the utility matches the technical specifications. More than one connection of the utilities may be required depending on the number of modules installed. Refer to specific wiring diagrams.

Utility	Requirements
Air supply for rejection device	Pipe size must be such that there will be no pressure decrease during machine operation. Air must be dry and free of oil.
Electrical supply	Provide one each electrical socket to comply with: <ul style="list-style-type: none"> <li>▪ <b>User interface electrical specifications</b> (on page 26) (use the specifications that apply to your system)</li> <li>▪ <b>Integrated tunnel electrical specifications</b> (on page 27) (if applicable)</li> <li>▪ <b>Cluster box electrical specifications</b> (on page 33) (if applicable)</li> </ul>
Internet connection (optional)	Provide a shielded ethernet cable to use Pressco's remote support through the Internet.

## Protective earthing

This product must be grounded (earthed). If it should malfunction or break down, grounding provides a path of least resistance for electric current to reduce the risk of electric shock.



Danger - Improper connection of the equipment grounding conductor can result in a risk of electric shock. Check with a qualified electrician or service technician if you are in doubt as to whether the product is properly grounded.

### Cord Connected Equipment

The product will be equipped with a supply cord having an equipment grounding conductor and a grounding plug. The plug must be plugged into an appropriate outlet that is properly installed and grounded in accordance with local codes and ordinances.

Do not modify the plug provided with the product - if it will not fit the outlet, have a proper outlet installed by a qualified electrician.

### Cable Direct

This product must be connected to a grounded metal, permanent wiring system, or an equipment grounding conductor must be run with the circuit conductors and be connected to the equipment grounding terminal.

## Electrical connection

Make sure that the power outlet voltage matches the voltage required by the machine. Refer to the specifications for equipment included with your system:

- **User interface electrical specifications** (on page 26)
- **Integrated tunnel electrical specifications** (on page 27) (if applicable)
- **Cluster box electrical specifications** (on page 33) (if applicable)



Warning - Power Switch is the power disconnect device. Do not position the equipment such that access to the disconnect switch is impaired. If not readily accessible (such as within a rack or mounting out of reach), an additional disconnect device should be installed that can isolate the Live and Neutral lines of the mains power supply, whilst leaving the protective earth intact.

## Installation

Pressco Technology Inc. recommends that the machine be **installed and assembled by Pressco's specialized technicians**. This is of vital importance for correct machine operation.



Warning - Pressco Technology Inc. shall not be liable in case of failures or damage to property and/or personal injury resulting from or connected with assembly if this has been carried out by unauthorized personnel, or is not in compliance with the indications given in this manual.

To carry out production and cleaning/ servicing operations, it is important for the machine to have a minimum amount of space all around and away from walls.

### Ventilation

Place the Pressco Intellispec components in a position with adequate ventilation to allow proper air flow through the air filters.

Component	Spacing
User Interface	Leave 1 meter [39 inches] clear around machine
Cluster box (not used on all systems)	Leave 100 mm clear in front of the fan and vent

### Stability of user interface

Ensure the stability of the user interface. Also refer to the directives in the **Personnel Safety** (on page 21) section.

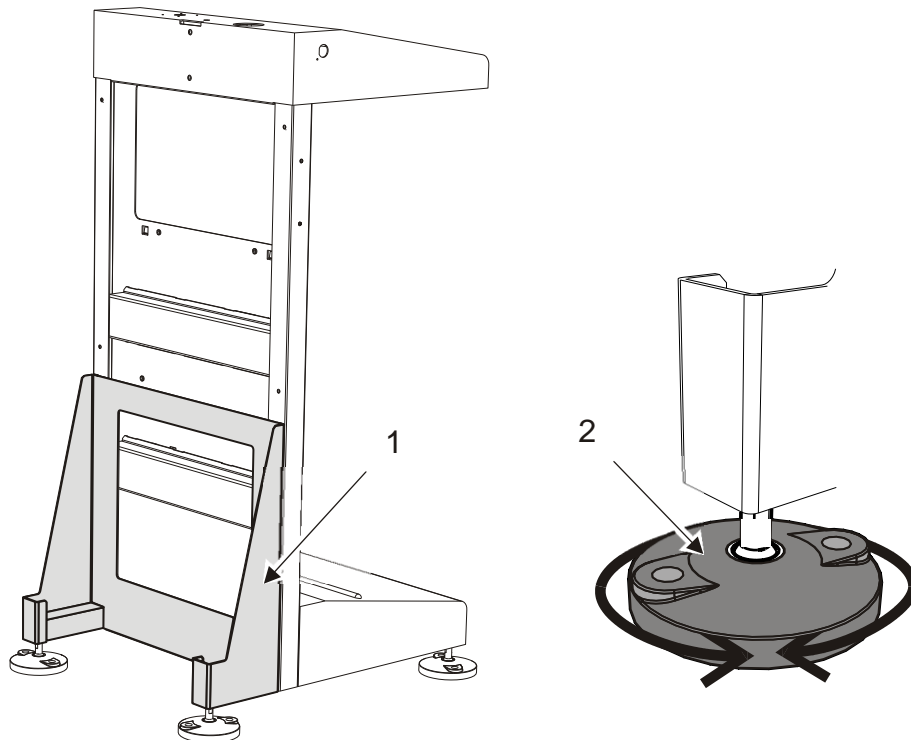

➤ **To make sure the user interface is stable:**

1. Make sure that the user interface stabilizer [item 1] is secured properly to the user interface.
2. Adjust the feet [item 2] to level the user interface. Proper leveling can help ensure proper operation.

# User Interface external connections

❖ Note: the connectors not called out in the diagram have no connection

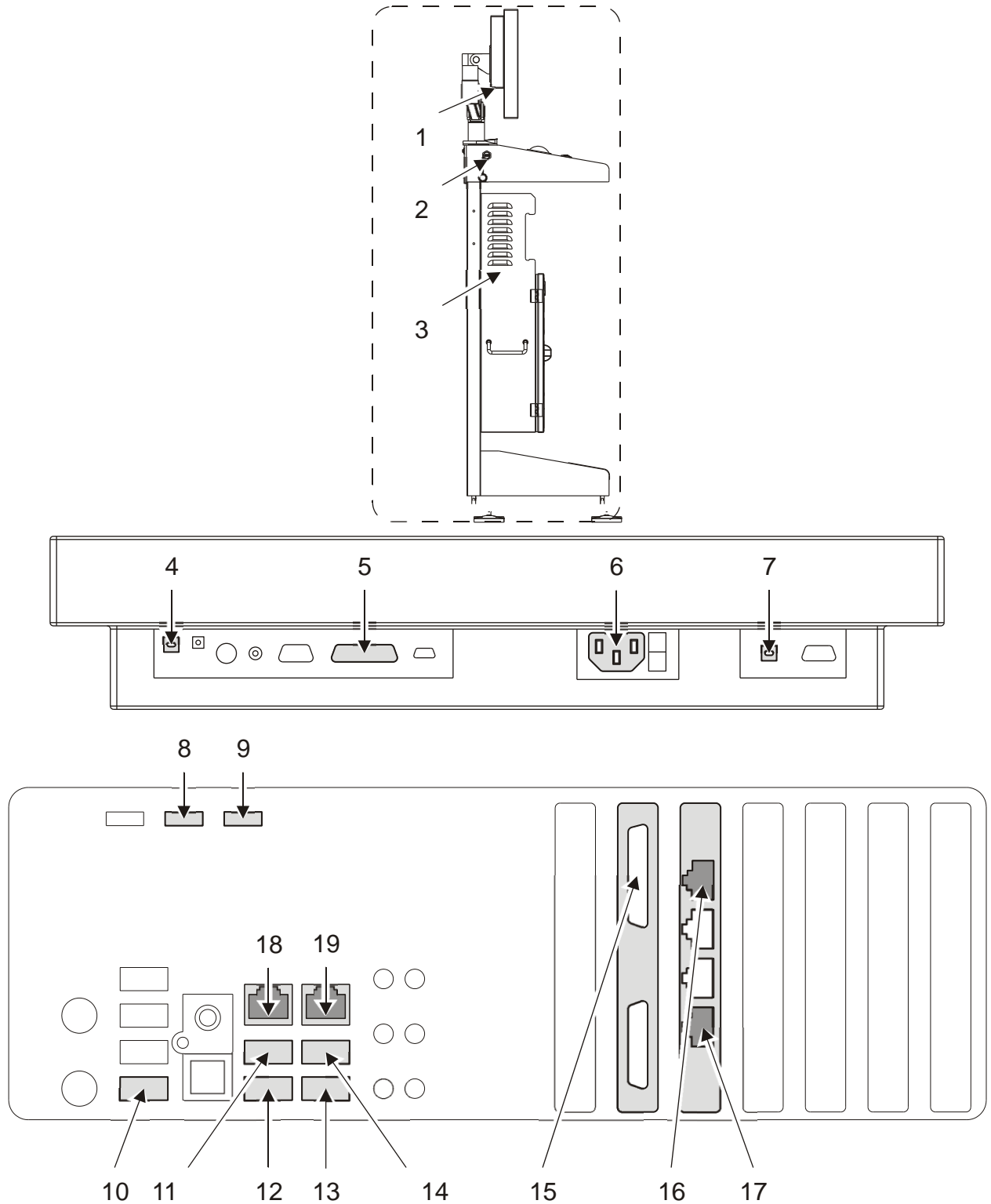

- 1) Monitor connector panel
- 2) Convenience USB port
- 3) PC [inside the cabinet]

### **Monitor connector panel connectors**

- 4) Auxiliary USB connector
- 5) DVI input
- 6) AC power connector
- 7) Touch screen USB connector

### **PC connectors**

- 8) 2 pin power connector for camera ethernet switch
- 9) 2 pin power connector for PDN ethernet switch
- 10) Convenience USB port connector
- 11) Monitor auxiliary USB connector
- 12) Monitor touch screen USB connector
- 13) Trackball USB connector
- 14) Biometric device USB connector
- 15) DVI connector
- 16) Ethernet connector for camera ethernet switch (blue cable)
- 17) Ethernet connector for PDN ethernet switch (green cable)
- 18) Optional plant network connection
- 19) Optional remote user interface connection

---

❖ *For more information, refer to **Wiring diagram user interface/ PC** (on page 45).*

---

## Pressco PC outlet wiring



Warning - The Pressco PC outlet is only to be used to provide power to the Intellispec PC. Any other use is prohibited.

The power connections for the user interface are found on the right side of the cabinet.

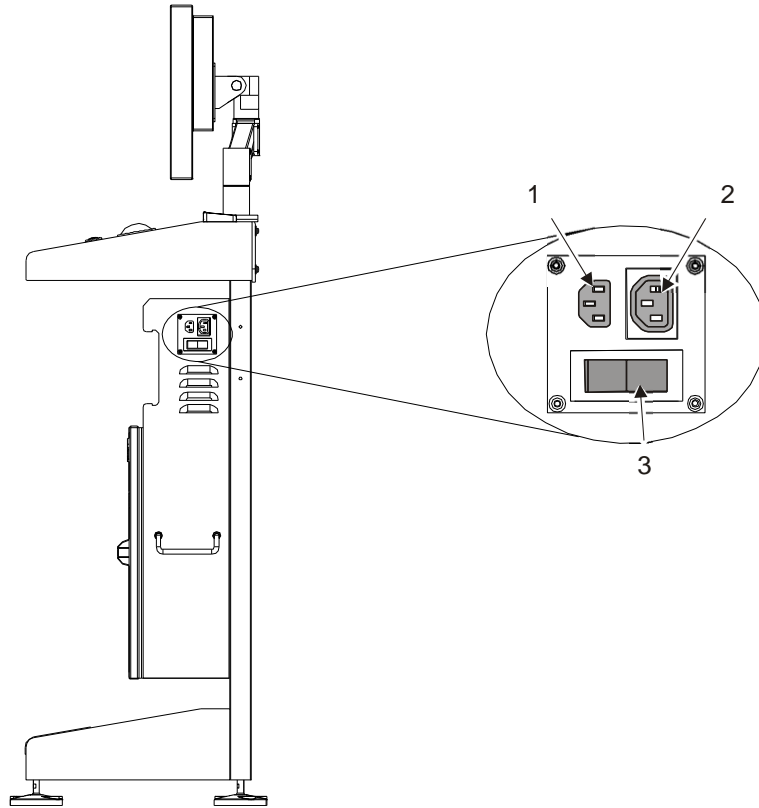

1) PC (computer) power connector

2) Monitor power connector

### 3) User interface power switch Wiring details:

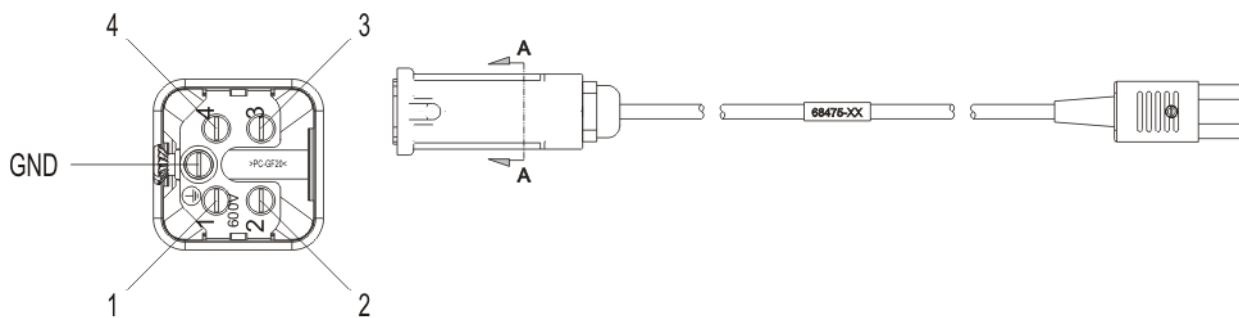

#### SECTION "A-A"

Output: 230VAC, 500W

Outlet mating connector: Harting: insert 09200042611, hood 09200031440



Use wire type UL1015 or equivalent, 16awg (1.44mm<sup>2</sup>) min.

Wiring chart			
Pin number, 5-pin connector	Wire color	Pin number, 3-pin connector	Description
1	black	L	L1
2	white	N	L2
GND	green	GND	PE

### Wiring diagram user interface/ PC

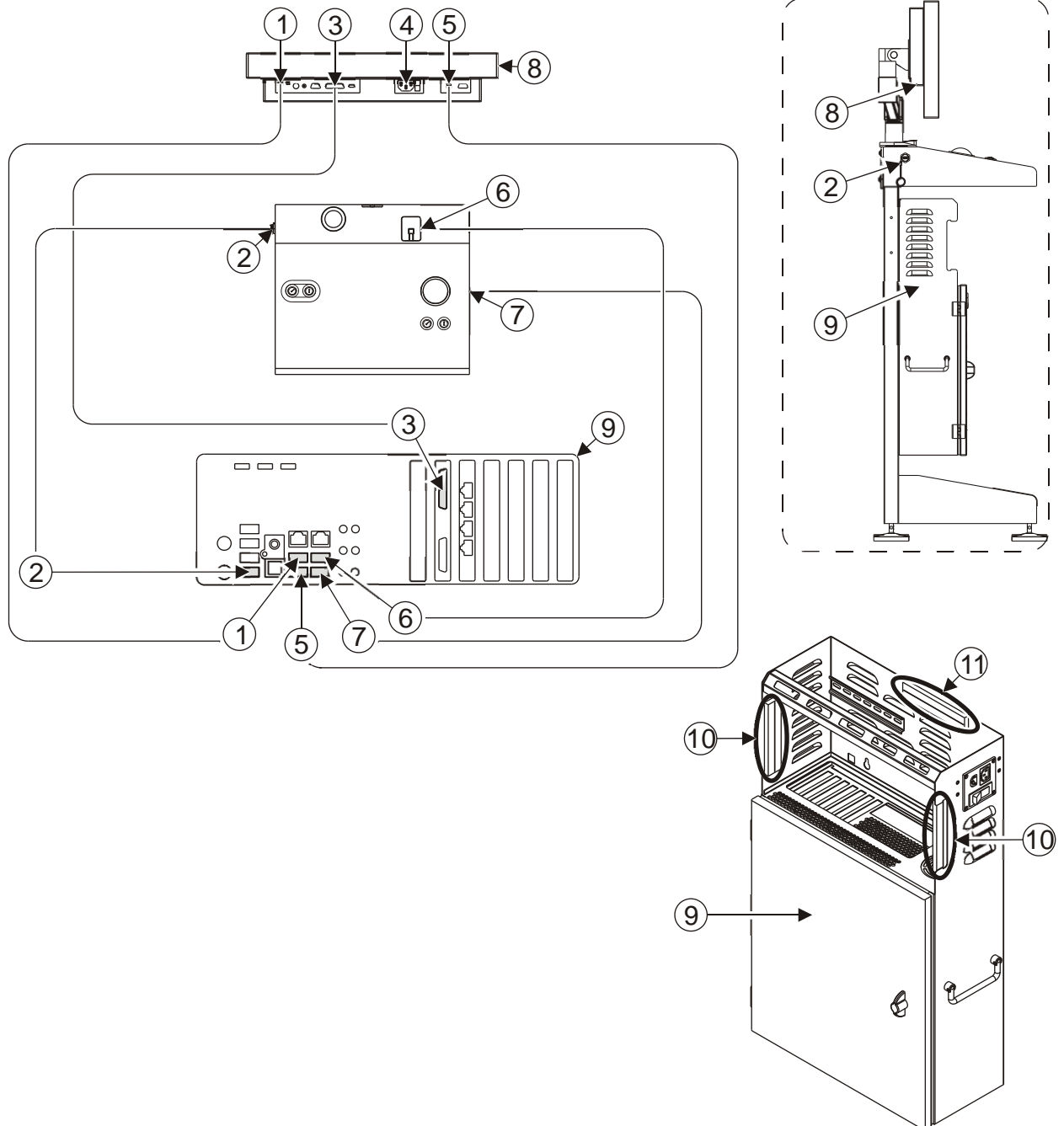
The following diagram shows the wire connections between the monitor, user interface, and PC.



- 1) Monitor auxiliary USB cable
- 2) Convenience USB port cable
- 3) DVI cable (included with monitor). (Remove DVI-VGA adapter if present)
- 4) AC power in for monitor
- 5) Touchscreen USB cable (for optional touchscreen monitor)
- 6) Optional Biometric device -USB cable.  Do not plug in until application software is installed.
- 7) Trackball USB cable.  Do not plug in the PS/2 connector.
- 8) View of monitor connector panel
- 9) PC. Connectors are inside cabinet.
- 10) Side cable entry locations
- 11) Cable entry. Route cables behind the PC mounting panel, through the cable entry at the back of the PC.

## Wiring diagram ethernet switches

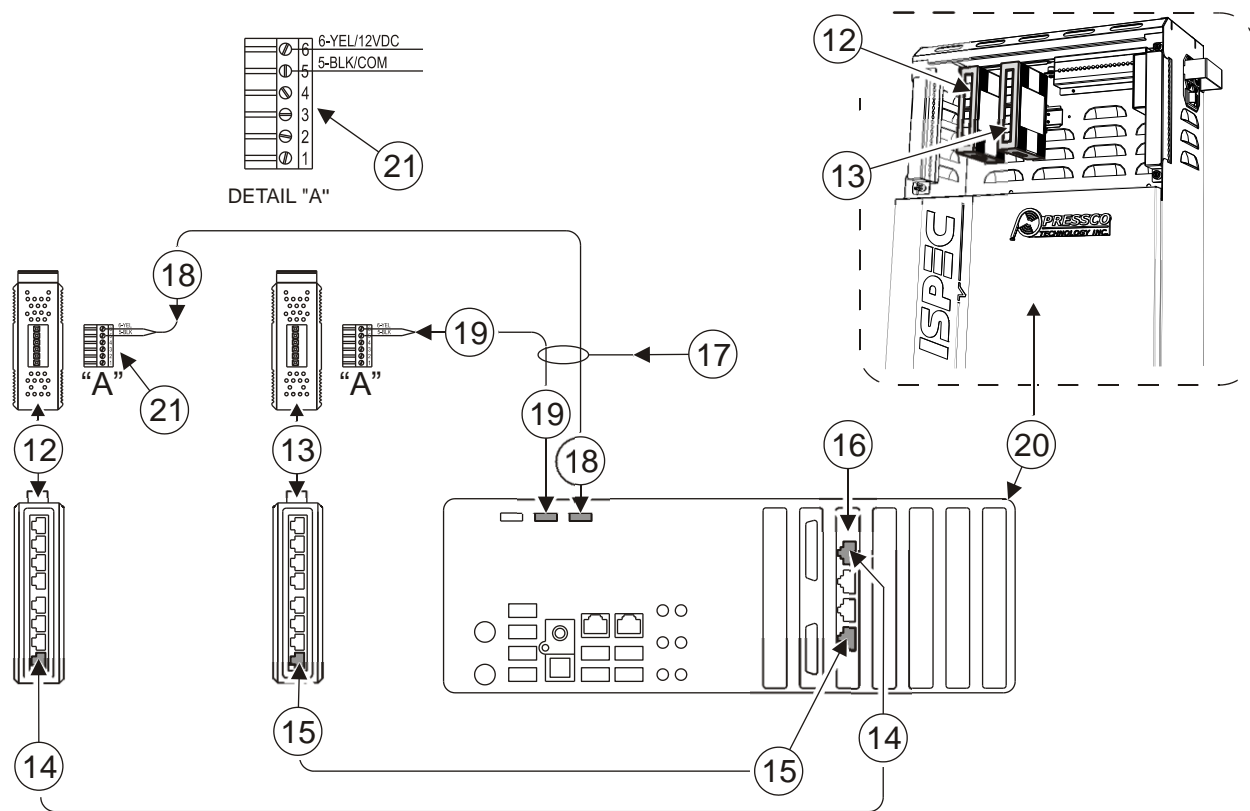

- 12) Ethernet switch for cameras [on left]
- 13) Ethernet switch for Pressco Device Network (PDN) [on right]
- 14) Blue ethernet cable
- 15) Green ethernet cable
- 16) Quad ethernet card
- 17) Two pin power connectors. Cables are included with PC.
- 18) Two pin power cable
- 19) Two pin power cable
- 20) PC
- 21) Detail "A" Ethernet switch power connection



J6) MP2 - Machine Part 2

J7) MP3 - Machine Part 3

J8) PKT - Pocket Detect

---

## Cluster box external connections

### Cluster Box Mains wiring

The mains voltage supply to the Cluster Box should be wired according to the following diagram. For voltage rating, refer to the *Cluster Box Electrical Specifications* (on page 33).

#### Wiring details:

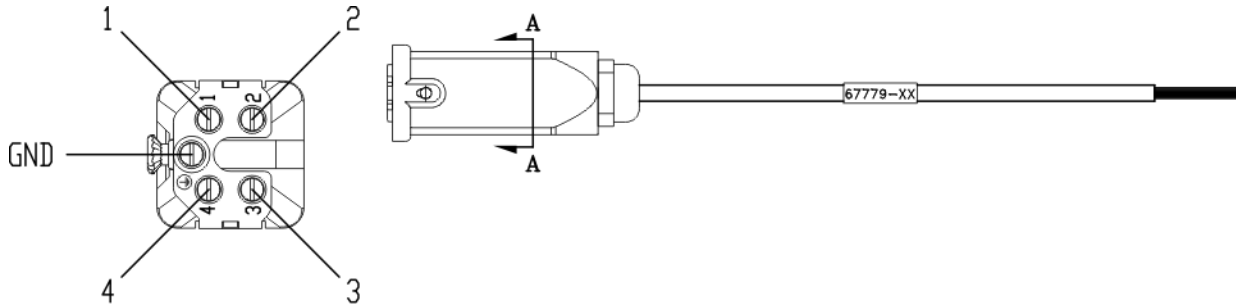

#### SECTION "A-A"

Mains mating connector: Harting: insert 09200042711, hood 09200031440

Use wire type UL1015 or equivalent, 16awg (1.44mm<sup>2</sup>) min.

Wiring chart		
Pin number, 5-pin connector	Wire color	Description
1	black	L1
2	white	L2
GND	green	PE

### Types of Cluster boxes

There are several types of cluster boxes that differ in size, external wiring, and voltage rating. Use the chart below to identify your cluster box.

For **external I/O connections**, determine whether your cluster box is a classic, embedded, wash-down, or micro model. The basic shapes are shown below:

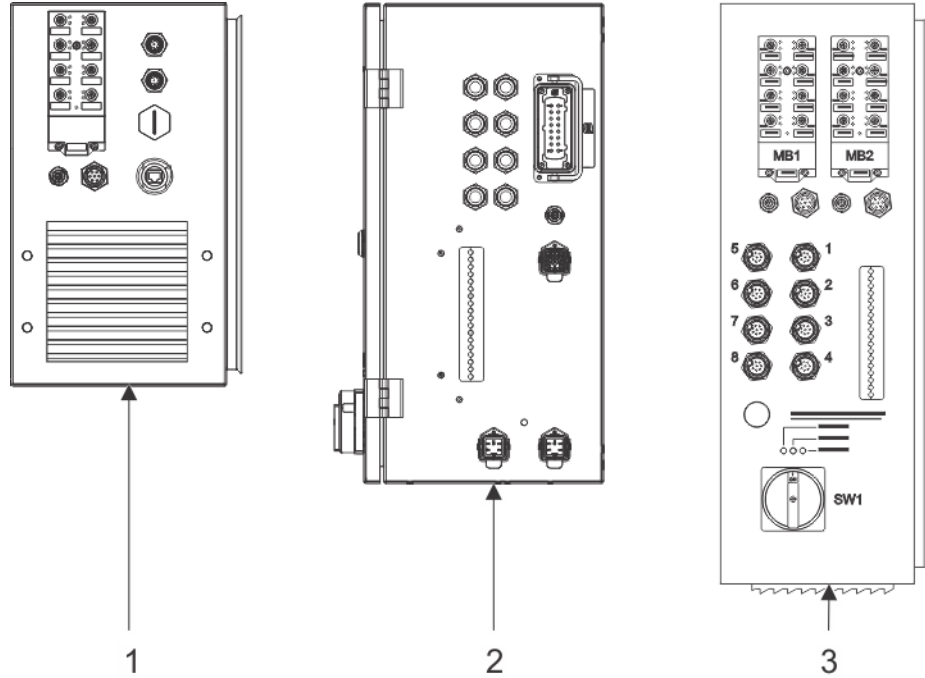

- 1) Micro or Wash-Down cluster box. Note: Wash-Down version has a protective cover over the filter and fan vents
- 2) Embedded cluster box
- 3) Classic cluster box

## Classic cluster box external connectors

❖ Note: the cluster box is not included with all systems

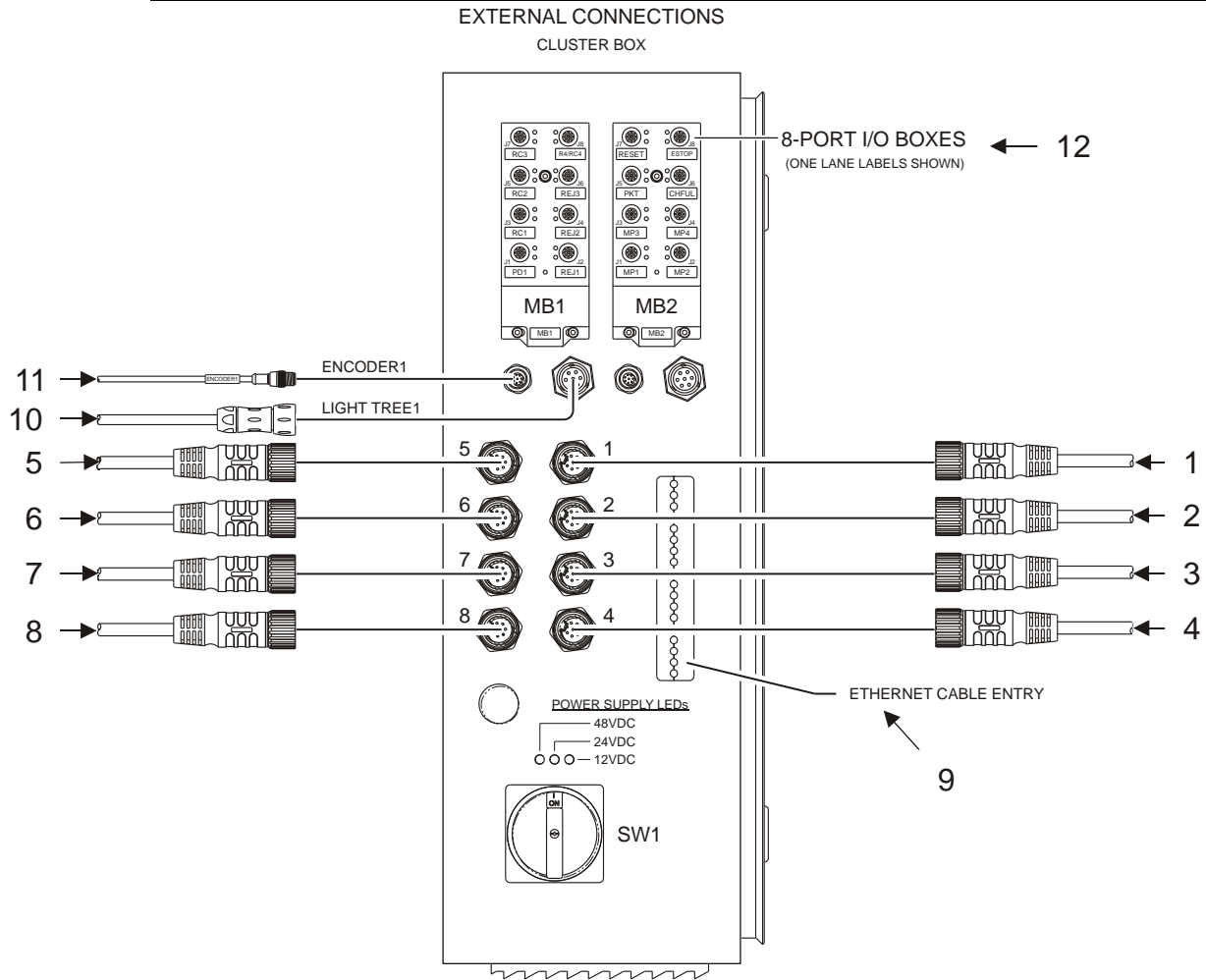

To connect sensors 1-8 and determine the number of network connections, refer to the **Cluster box system configurations** (on page 54).

- 9) Ethernet cable entry
- 10) Light Tree 1
- 11) Encoder 1
- 12) **8 port I/O boxes** (on page 51)

## 8 port I/O boxes

8-PORT I/O BOX-MB1

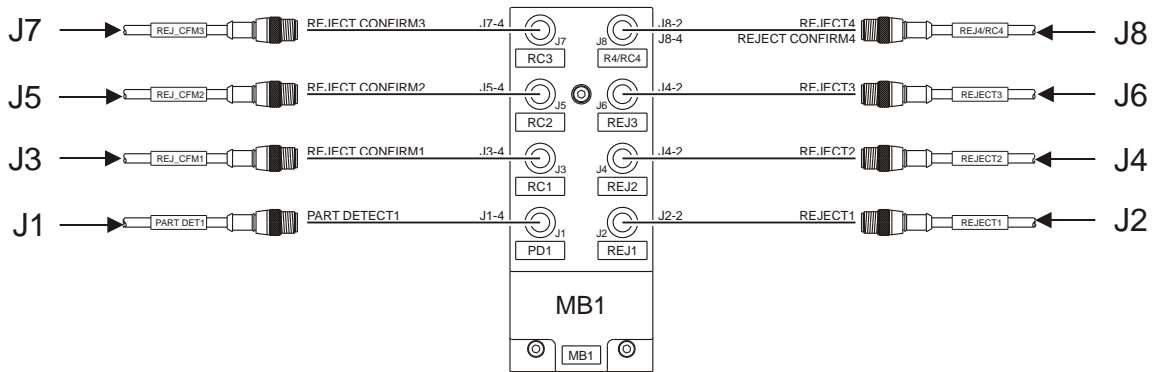

8-PORT I/O BOX-MB2

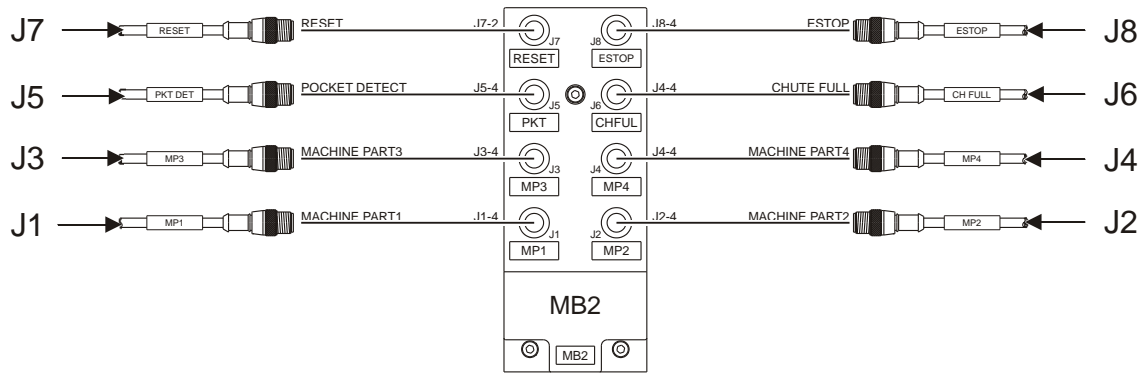

8 port I/O box MB1		
J1	PD1	Part detect 1
J2	REJ1	Reject 1
J3	RC1	Reject Confirm 1
J4	REJ2	Reject 2
J5	RC2	Reject Confirm 2
J6	REJ3	Reject 3
J7	RC3	Reject Confirm 3
J8	R4/ RC4	Reject 4/ Reject Confirm 4

8 port I/O box MB2			For typical base/neck/ seal configuration in a blow molder
J1	MP1	Machine Part 1	Cavity
J2	MP2	Machine Part 2	Spindle
J3	MP3	Machine Part 3	Infeed transfer arm
J4	MP4	Machine Part 4	
J5	PKT	Pocket Detect	
J6	CHFUL	Chute Full	
J7	RESET	Reset	
J8	ESTOP	Emergency stop	

***Embedded Cluster box external connections***

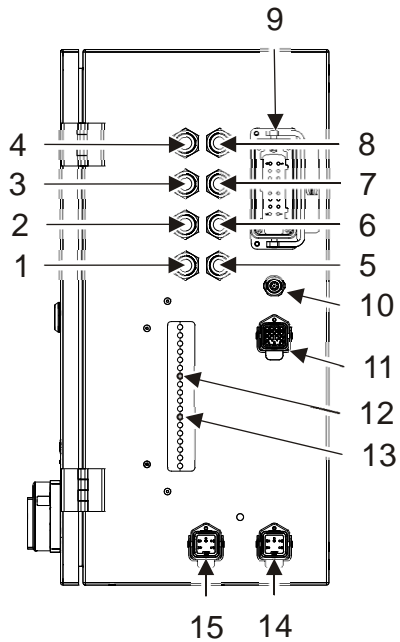

To connect sensors 1-8 and determine the number of network connections, refer to the **Cluster box system configurations** (on page 54).

9) To PCC (programmable controller)

10) Pressco encoder

11) Light tree and horn

12) PDN network (green)

13) Sensor network (blue)

14) 230 V to Pressco PC

15) 400 V supply

## Wash-Down and Micro Cluster box external connections

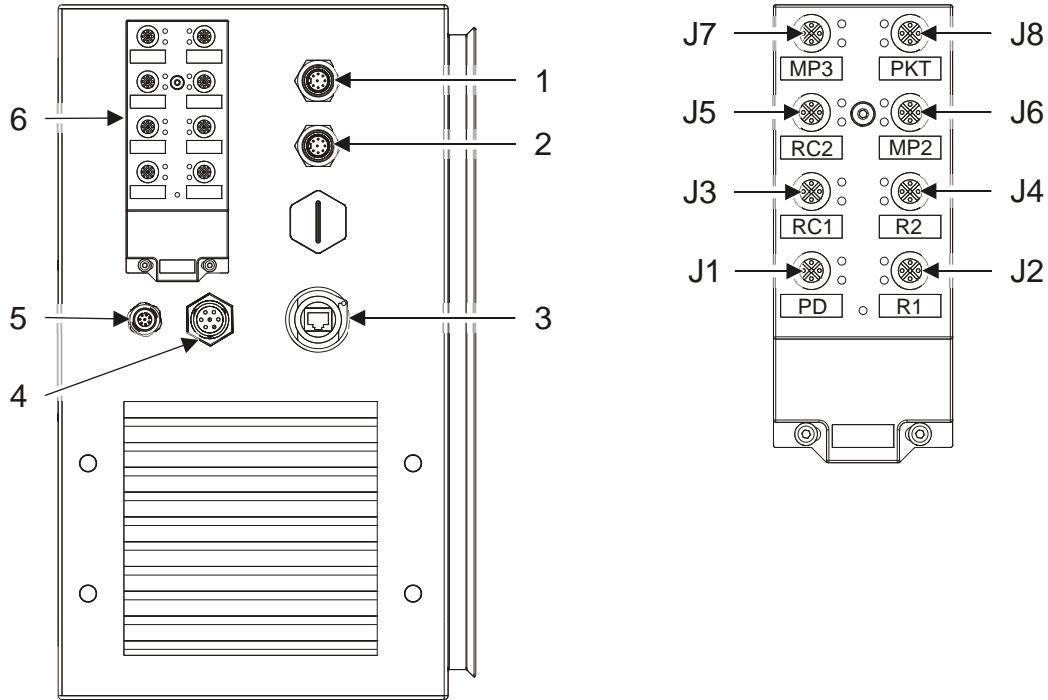

❖ Note: the Wash-Down version of this box has a protective cover over the filter and fan vents

1	Sensor 1
2	Sensor 2
3	PDN network (green)
4	Light tree and horn
5	Encoder
6	8 port I/O box (refer to table below)

❖ Note: Sensor network (blue) cable goes directly from the sensors to the Intellispec computer

J1	PD	Part Detect
J2	R1	Reject 1
J3	RC1	Reject Confirm 1
J4	R2	Reject 2
J5	RC2	Reject Confirm 2
J6	MP2	Machine Part 2
J7	MP3	Machine Part 3
J8	PKT	Pocket Detect

## Cluster box system configurations

Eight-sensor cluster boxes should be wired according to the configuration in the following tables. Please note the following:

- Starting with port 1 – connect the modules in order, skipping a connection if and only if the module just connected has two cameras (2 camera sidewall and PSE).
- Label the cables on the cluster box side with matching designations (1 to 8). Label the other end of the cable with the module name.
- Modules are to be connected in the order listed here:
  - 1) Base
  - 2) Neck or Sidewall
  - 3) Seal
  - 4) Preform Seal/Endcap
  - 5) Preform Wall
  - 6) IMASS Base
  - 7) Imass Wall (uppermost)
  - 8) Imass Wall (next uppermost)

Use the table below that matches your system configuration, and connect the modules accordingly.

- [\*] T connection to lighting controller
- [+] Module connects to endcap lighting

Chan -nel	B2WS- PSEPW- M	BNS- PSEPW- M2	BNS-M3	BWS- PSEPW- M2	B-PSEPW -M	B-M2	PSEPW- M	NS- PSE
1	Base*	Base*	Base*	Base*	Base*	Base*	PSE+	Neck*
2	Sidewall	Neck	Neck	Sidewall	PSE+	Imass Base	-	Seal
3	-	Seal	Seal	Seal	-	Imass Wall	PW	PSE*
4	Seal	PSE+	Imass Base	PSE+	PW*	-	Imass	-
5	PSE+	-	Imass Wall	-	Imass	-	-	-
6	-	PW*	Imass Wall	PW*	-	-	-	-
7	PW*	Imass Base	-	Imass Base	-	-	-	-
8	Imass Base	Imass Wall	-	Imass Wall	-	-	-	-

Network Connections		
(1) indicates one network cable connection, (2) indicates two network cable connections		
Module	PDN (green)	Data (blue)
Base	1	1
Neck	-	1
Sidewall	-	1
Sidewall (2 camera)	-	2
Seal	1	1
PSE	2	2
PW	1	1

<b>Network Connections</b>		
(1) indicates one network cable connection, (2) indicates two network cable connections		
Imass	1	-
Controller	1	-
Computer	1	1

## Replacing fuses in the cluster box



Warning - For continued protection against fire hazard, replace fuses only with the same type and ratings. The use of other fuses or materials is prohibited.



Warning - Disconnect the product from the mains supply before replacing the fuse(s).

For fuse rating, refer to the table below pertaining to the **type** (see "**Types of Cluster boxes**" on page 48) and voltage rating of your cluster box.

❖ *Note: the Wash-Down and Micro Cluster boxes do not contain replaceable fuses.*

<b>Classic Cluster box 120VAC fuses</b>		
<b>Part Number</b>	<b>Fuse</b>	<b>Value</b>
66780	FU1	5A, 600VAC, Time Delay, Class CC
59164	FU2	0.5A, 250VAC, 5x20mm

<b>Classic Cluster box 230VAC fuses</b>		
<b>Part Number</b>	<b>Fuse</b>	<b>Value</b>
65345	FU1	3A, 600VAC, Time Delay, Class CC
65345	FU2	3A, 600VAC, Time Delay, Class CC
51818	FU3	0.5A, 250VAC, 5x20mm
❖ <i>Note: Fuse kit 66990 is available. It contains all the above fuses.</i>		
<b>Classic Cluster box 400VAC fuses</b>		
<b>Part Number</b>	<b>Fuse</b>	<b>Value</b>
65345	FU1	3A, 600VAC, Time Delay, Class CC
65345	FU2	3A, 600VAC, Time Delay, Class CC
65346	FU3	10A, 600VAC, Time Delay, Class CC
51818	FU4 (quantity 2)	0.5A, 250VA, 5x20mm
❖ <i>Note: Fuse kit 66990 is available. It contains all the above fuses.</i>		
<b>Embedded Cluster box fuses</b>		
<b>Part Number</b>	<b>Fuse</b>	<b>Value</b>
65345	FU1	3A, 600VAC, Time Delay, Class CC
65345	FU2	3A, 600VAC, Time Delay, Class CC
65346	FU3	10A, 600VAC, Time Delay, Class CC
51818	FU4 (quantity 2)	0.5A, 250VAC, 5x20mm
❖ <i>Note: Fuse kit 66990 is available. It contains all the above fuses.</i>		

---

## **Commissioning**

Before placing the machine into operation, make sure the following checks are completed:

<b>Completed</b>	<b>Yes</b>	<b>No</b>
Positioning and leveling of the unit		
Connection of compressed air line to connection points		
Connection of power supply to vision processor cabinet		
Connection of power supply to cluster box (if applicable)		
Connection of power supply to integrated inspection module(s) if applicable		
Proper wiring from user interface cabinet to sensor module(s) and cluster box (if applicable) using the wiring diagrams		



# Chapter 6

## Operating the Intellispec Series V System

### Power Up

Intellispec Series V systems have multiple power switches. Make sure the power switches are turned on for the user interface, each camera module, and cluster box (if applicable). See the illustrations below for power switch locations.

The power connections for the user interface are found on the right side of the cabinet.

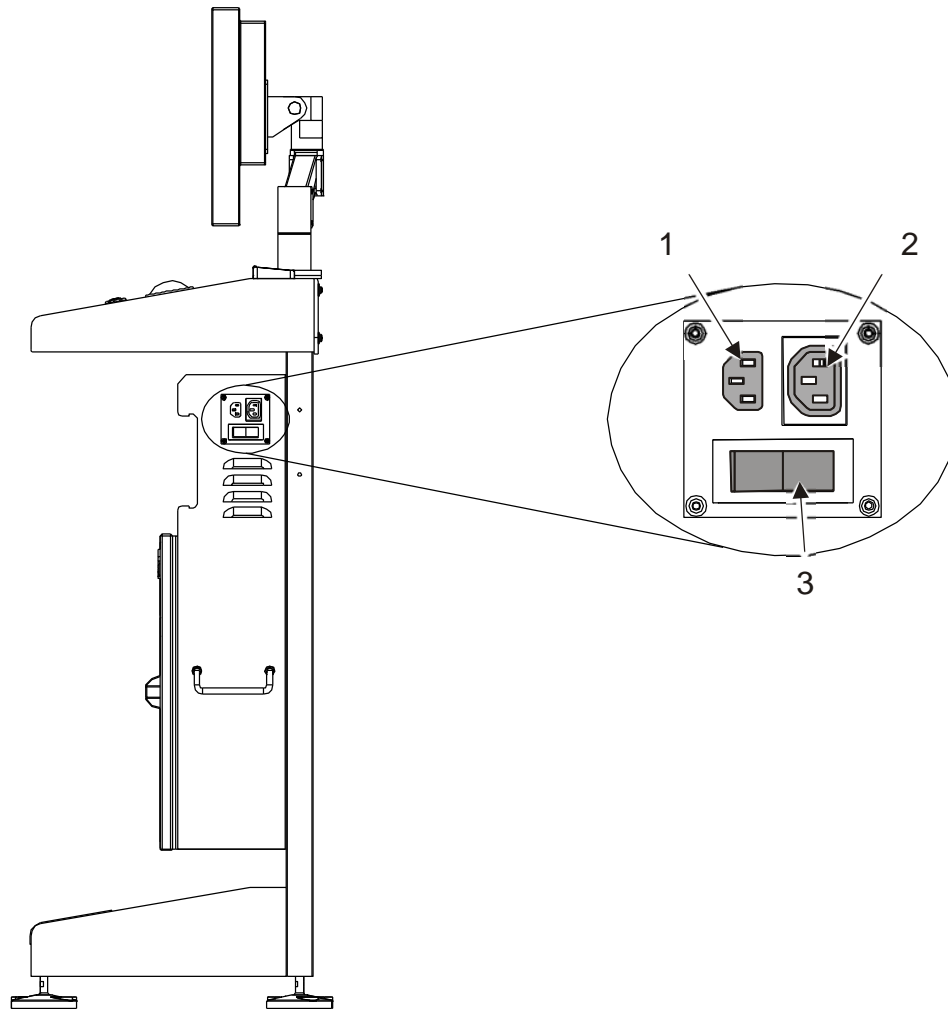

- 1) PC (computer) power connector
- 2) Monitor power connector

3) User interface power switch Each integrated camera module (for example the CPV series of inspection tunnels) has its own power on/off switch.

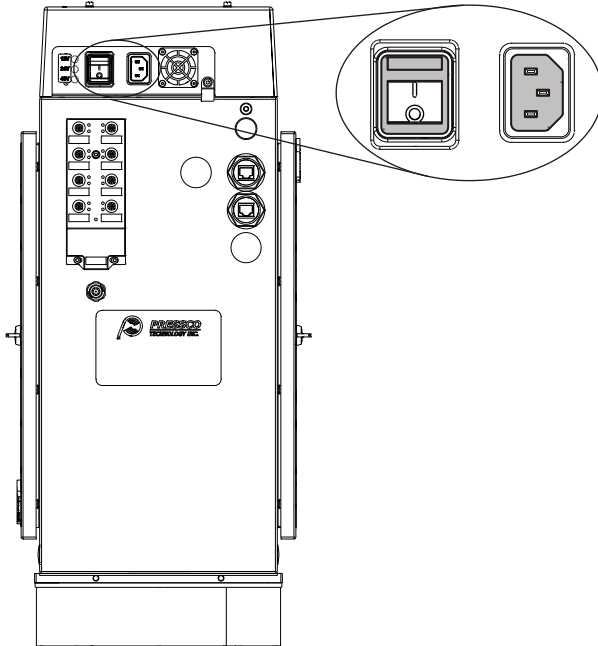

In system configurations that have a cluster box:

- if the cluster box has a UPS, open the cluster box door and switch on the UPS, then
- turn the external on/off switch to power all camera modules connected to the cluster box.

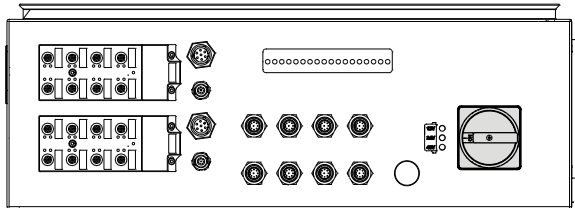

## Power Down

To completely power down all components of the Intellispec, make sure the following power switches are turned off:

- User interface
- Integrated inspection modules (if applicable)
- Cluster box (if applicable)
- UPS inside the Cluster box (if applicable). Open the Cluster box door to switch off the UPS.

The user interface, inspection modules, and cluster box are all independent of each other. Therefore, if you need to service any of the above modules, any one can be turned off by itself.



Important - If you re-start the computer, turn off the User Interface power and leave it off for about 40 seconds before turning it back on. This allows the electronic components to correctly reset.

To see the locations of the power switches, refer to **Powering on the system** (see "**Power Up**" on page 59).

---

## Online / Offline



- The stoplight is the online/offline indicator for each lane. **Red** = offline; **green** = online; **amber** = smart offline (processing parts in the queue when the system goes offline).
- To switch from the online to offline mode, or vice versa, click the stoplight.
- Lanes can be put online or offline independently. If multiple lanes are configured, then one lane can be offline while another is online.

---

## Part Changeover

❖ *Note: Some menu items are only available to advanced level users.*

➤ **What you need:**

- User permission to Switch Part Program

➤ **To change parts:**

1. **Log in** (see "**Log in and log out**" on page 73).
2. Click the part drop-down menu.

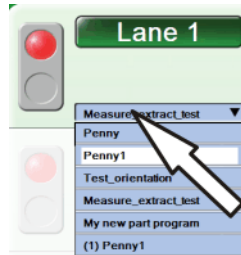



3. Click the name of the new part to inspect. The new part program is loaded on the Intellispec.
4. Put the lane online to begin inspecting new parts.

---

## Exiting the Intellispec software

You must have proper user permissions to exit the software. This prevents unauthorized system shutdowns. Contact your system administrator if you need user permissions.

➤ **To exit Intellispec software:**

1. Log in.
2. Select Home  | Tools  | **Exit System.**
3. Select an option.

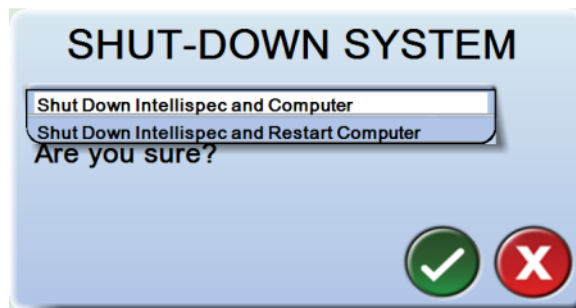

4. Select the OK  button. The Intellispec software and/or computer shuts down (and restarts if applicable).



# Chapter 7

## Intellispec cabinet and user interface

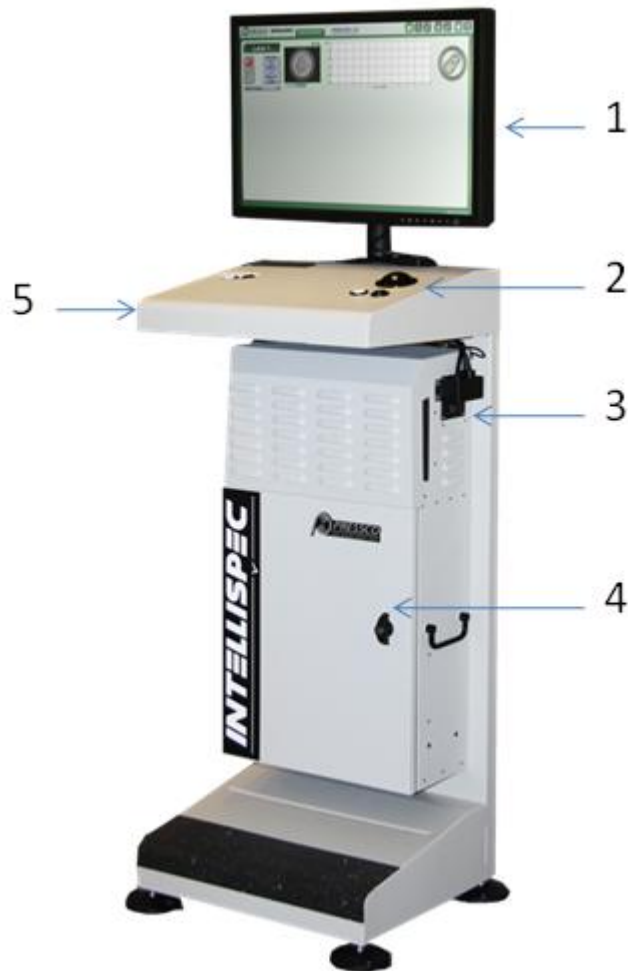

- 1) 24" Diagonal color LCD with optional touch screen. An on-screen keyboard (OSK) is displayed when needed.
- 2) Trackball with two sets (left-handed or right-handed) of buttons: Select buttons [✓] and Information buttons [i]
- 3) Vision processor on/off switch.
- 4) Inside the cabinet: Ethernet switches, Vision processor, Mechanical keyboard (MKB)
- 5) USB convenience port is mounted on the side of the user interface.

---

### User interface input devices

The following devices are available to input information to the Intellispec system:

- **Trackball and buttons** (see "**How to select menu items**" on page 64)
- **On Screen Keyboard (OSK)** (on page 70)
- Touch Screen monitor (optional)
- Temporarily connected conventional **Mechanical Keyboard (MKB)** (on page 65)
- **USB Ports** (on page 65)
- Optional Biometric Identification login **device** (see "**Biometric login device**" on page 66)

## User interface selection devices

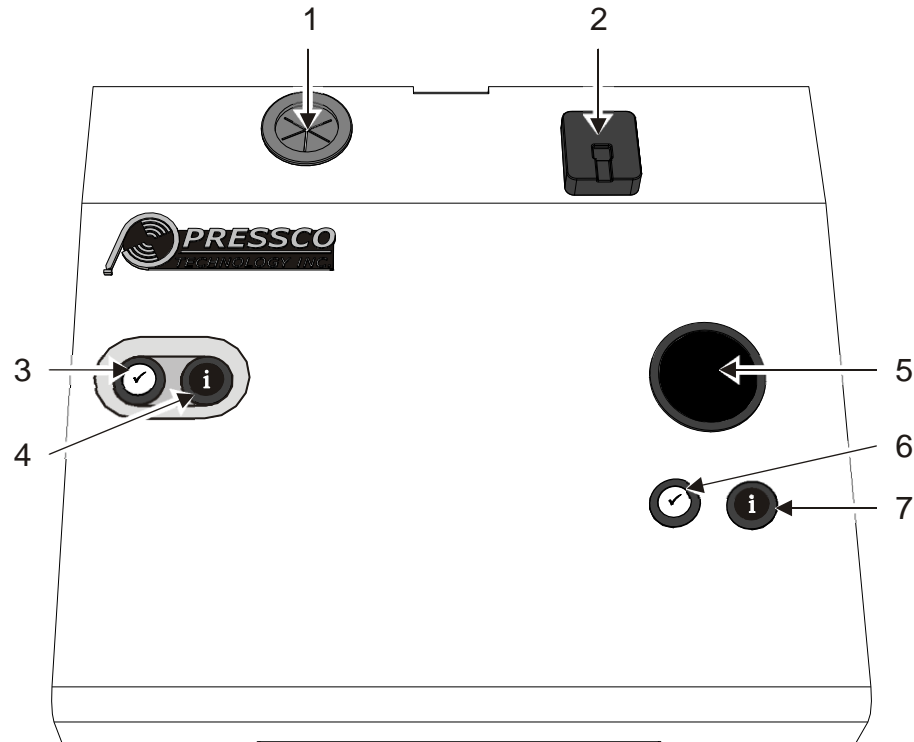

The user interface hardware consists of several buttons and selection devices:



- 1) (not a button) Grommet for user interface equipment cords.
- 2) Optional Biometric Identification login device
- 3 and 4) Secondary set of buttons, used with track ball. See also items 6 and 7.
- 5) Track Ball
- 6) Button (left-click) to select and activate objects on screen
- 7) Button (right-click) to call up a context-sensitive menu about the selected object on screen

## How to select menu items

Use the track ball to select, interact, and change active objects on the screen. The track ball will be required for all inspection editing tasks.

Use the left button [  ] to select and activate objects on the screen. Use the right button [  ] to call up a context-sensitive menu related to the area or object clicked. A second set of each button type is located on the left side of the podium for two-handed operation.

---

❖ *Note: Swapping the button assignments is not supported. The second set of buttons is to accommodate left-handed users.*

---

Action	Result
Point (move pointer with the track ball)	Display Tool Tip when hovered over active object
Click (Left-click) ✓	A click initiates various actions. Nothing happens when the pointer is clicked on a disabled object.
Double-click ✓ ✓	A double-click initiates various actions. For example, edit an inspection.
Right-click ⓘ	Display a context-sensitive menu when you click on an enabled object. The context-sensitive menu often contains functions that are also available in a menu bar or other screens. For example, add a point to a polygon.
Drag (hold the left button while moving the track ball)	Examples: move a selected Region of Interest (ROI) around an image or move an inspection in a Tree View to change the order of execution.

## Mechanical keyboard (MKB)

The system supports the temporary connection of a conventional mechanical keyboard using one of the available **USB ports** (on page 65). This keyboard will mostly be used for system level tasks such as BIOS configuration, Network configuration, and System level setup.



The keyboard:

- Is primarily used by Pressco Field Service Engineers
- Is stored inside the Vision PC chassis
- Requires a stable location when in use

## USB Ports

There are USB ports available to back up or transfer data, and also to connect the optional mechanical keyboard. One is mounted on the side of the user interface pedestal.

Some touch screen monitors have additional USB connectors on the side of the monitor.

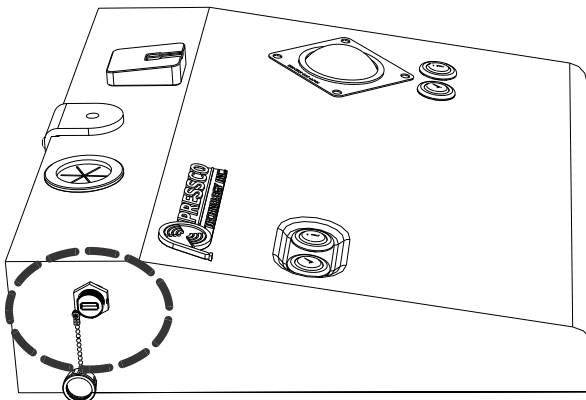

## Biometric login device

The Biometric Identification login device is used to log in and out of the Intellispec system. This device is optional and must be purchased with the system.



To log in with this device, press your finger to the device. The following are conditions for use:

- You must use the same finger as initially set up by your administrator
- If you do not know how your account was set up (or which finger you used), contact your administrator
- If, after three tries, the Intellispec does not recognize your finger print, you must log in using the **on screen keyboard (OSK)** (see "**On Screen Keyboard (OSK)**" on page 70))

# Chapter 8

## Software Overview

This section describes the regions of the user interface and how to navigate through the software. It also describes how to select items and how to use the user interface buttons.

### User Interface Display - Four Levels

The display on the user interface has four levels for viewing:

❖ *Note: when you switch between System Overview and Lane Overview modes, you will see one screen 'minimize' to the task bar while your selected screen is displayed. This is normal.*

➤ **To view the four viewing levels:**

1.  Select Home to go to level 1, System Overview.
  - **System Overview** - Displays information that represents the complete system as well as a thumbnail line for each Lane that is configured.

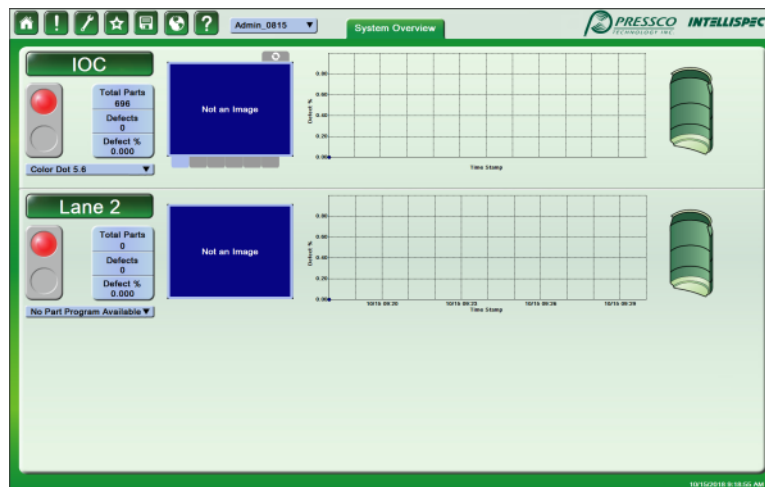

2.  Select a Lane button to go to level 2, Lane Overview.
  - **Lane Overview** - Displays information for a particular Lane as well as images for each sensor used in that Lane.





---

## Statistics menu

Use the Statistics menu in the Lane Overview screen to view, reset, or print statistics.

❖ *Note: Some menu items are only available to advanced level users.*

To view the Statistics menu: Select a Lane button **Lane n** | Click over a statistics box.

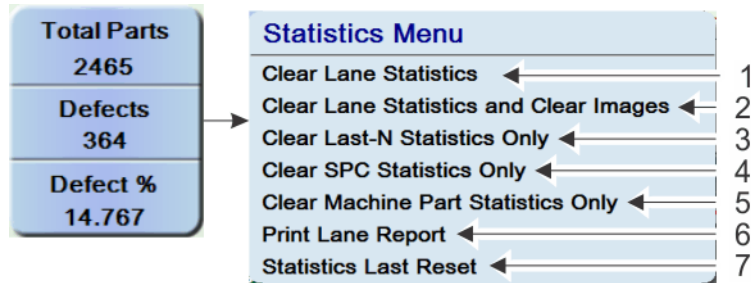

### 1) Clear Lane Statistics

Clear the statistics for the lane only.

### 2) Clear Lane Statistics and Clear Images

Clear the statistics for the lane and empty the defective image buffer.

### 3) Clear Last-N Statistics Only

Clear the statistics for the Last N and Last N% parts in the corresponding graphs. **Statistics Grid options** (on page 87)

It also clears the counts for population-based alarms, and clears such alarms that are currently triggered. (includes: Percent Defects, Good Parts, Percent Rejects, Excessive Rejects, Excessive Warnings, and Consecutive Defects)

### 4) Clear SPC Statistics Only

(Only available if you have Retro-Spec inspections enabled to keep SPC data) Clear the statistics statistical process control. See Statistical Process Control.

### 5) Clear Machine Part Statistics Only

(Only available if machine part correlation is enabled on your system) Clear the statistics for the machine parts. See Machine Part Correlation.

### 6) Print Lane Report

Send the lane statistics report to the default configured printer.

### 7) Statistics Last Reset

Display the date and time when the lane statistics were last reset.

---

## On Screen Keyboard (OSK)

Keyboards will be displayed depending on what kind of input is needed. Other keys are available, depending on your language. Keys may be grayed out if not applicable to the current operation.

### *Alphanumeric keyboard*

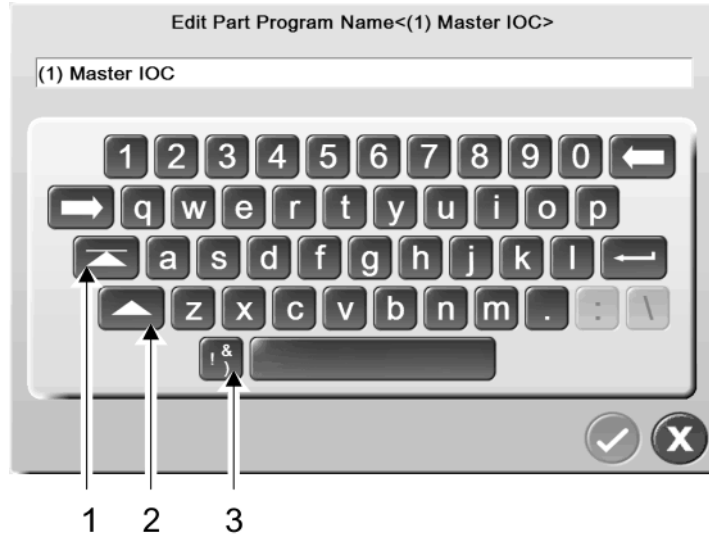

- 1) - **Shift lock** button - capitalizes all letters until you press this button again.
- 2) - **Shift** button - capitalizes one letter, then returns to uncapitalized letters automatically.
- 3) - **Symbols** button - provides additional keys, shown below.



**Latin key:** This key, available in some languages, allows you to enter Latin characters. This is required for entering some system-level items, including file extensions.



### *Numeric keyboard*

The numeric keyboard is displayed when the input field requires a numeric entry. Most of the buttons are self-explanatory. Additional buttons are described below.

---

❖ Note: some buttons are not displayed if they are not appropriate for that field.

---

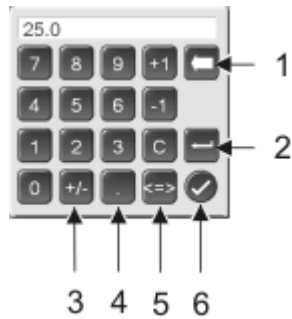

- 1) **Backspace** - removes a digit
- 2) **Enter** - populates the field in the Intellispec screen without closing the keyboard. This is useful if you want to test a value and see the results of the change immediately.
- 3) **[+/-]** makes the number positive or negative
- 4) **[.]** available only if a decimal number is valid in the input field
- 5) **[<=>]** cycles to the next limit of the parameter. If the parameter has more than two limits, then asterisks will surround the selected value in the menu.

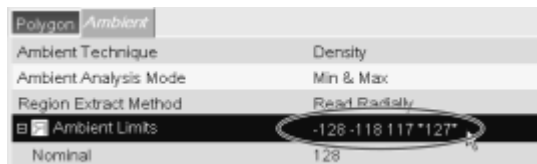

- 6)  accepts your changes and closes the numeric keypad

---

## Menu Toolbar



- 1) Home - Go to the System Overview Screen
- 2) Alarms- Clear, view, and set alarms
- 3) **Tools menu** (on page 99) - Configure system settings, reports, hardware, part tracking, rejectors, part setup, and more
- 4) Star menu - Take screen shots and manage background tasks
- 5) Back Up and Restore Menu - Create a support package, restore the system from a support package, and launch Windows Explorer
- 6) **Language** (on page 71)
- 7) **Help** (on page 72) - Access the help documents, remote support, and determine software version

## Language

-  Select a language.



Caution: The Language settings dialog (shown below) is the only place to change language, including number and date/time formatting. These settings must NOT be made in the Windows configuration, where the computer's locale must remain at US English. Otherwise, you may encounter errors and lose critical information.

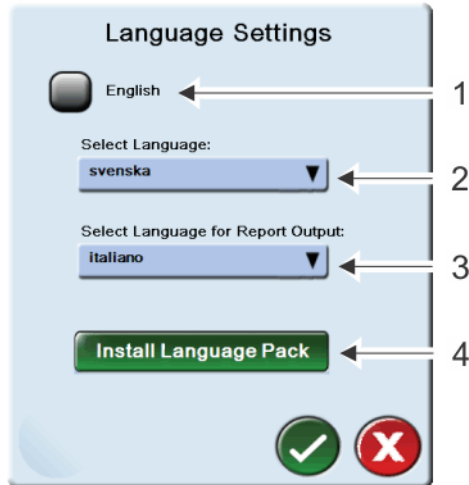

#### 1) English

If this box is checked, the names of the available languages are displayed in US English (example: *Swedish* instead of *svenska*).

#### 2) Select Language

Select the language to display on the user interface.

#### 3) Select Language for Report Output

Select the language for the reports, such as the Lane Report from the **Statistics menu** (on page 69).

#### 4) Install Language Pack button

When a new language is available, use this option to install the proper files. You will receive instructions from Pressco to install the language pack.

## Help



Select the Help icon to:

- use the system manuals
- access Pressco remote support
- obtain your current software version

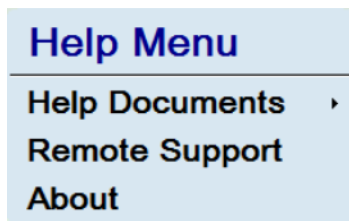

#### ➤ To access the user manuals:

1.  Select the Help icon.
2. Select Help Documents, then select a manual from the list. The user manual is displayed.

# Chapter 9

## User Accounts and Login information

---

### Log in and log out

➤ *To log in:*

-  Select the **Log In** button. Enter your password.
- With the optional **biometric sensor**: Press your finger to the sensor.
  - The system logs you in. If the system fails to recognize your identity after three attempts, then log in through the log in dialog box.

➤ *To log out:*

-  Select the button with your name, then select the **Log Out** button.
- With the optional **biometric sensor**: Press your finger to the sensor. The system logs you out.

❖ *Note: When another user logs in, the system automatically logs you out.*

---

### Switch users

The Switch Users option from the Log In menu logs out the current user, and allows a new user to log in.

➤ *To switch users:*

1. Click the Log in button (which has the current user's name displayed).
2. Select Switch Users from the menu.
3. Select the new user name from the drop-down menu.
4. Enter the new user's password. The new user is logged in. The previous user is logged out.

➤ *If you have a biometric sensor:*

Press your finger to the biometric sensor device to log in. The previous user will be automatically logged out by the system.

---

### Change your password

The Change Password function is available to all users.

❖ *Note: an Administrator can reset a password if necessary.*

---

➤ *To change your password:*

1. Log in.
2. Select the Log In button to see the Log In menu.
3. Select Change Password. The Change Password dialog box is displayed.
4. Enter your Old Password.
5. Enter a New Password.
6. Confirm your New Password.
7. Select the OK button  to accept the changes. The dialog box closes and your password is changed.



# Chapter 10



## Alarms

There are five types of alarms: System, Lane, Sensor, Rejector, and Machine Part alarms. Most of these are configurable (except the System Alarms - UPS and over temperature).



The information in this section is valid in software versions 5.6.010, 5.7.008 and higher.

❖ *Note: Alarms are recorded in the system log reader (on page 99), even when the alarms are automatically cleared.*

### View/ Clear Alarms

 Select the Alarm button to get to the **View/Clear Alarms** dialog. If no alarm is active, click  | **View/Clear Alarms**.

The indicators in this screen show whether an alarm is enabled, and whether it is triggered.

-  Red On - the alarm is both enabled and triggered
-  Green On - the alarm is enabled, but has not been triggered
-  Green Off - the alarm is not enabled nor triggered

Select different tabs to see more alarms. The tabs (except Lane) have sub-tabs which contain information about specific alarms. If any alarm is raised in a sub-tab (Sensor 1 in our example), then the container tab (Sensor) also shows an alarm.

Select any indicator to see alarm details. You can also do this if an alarm is not active. See also **Machine Part Alarms - View/Clear** (on page 82)

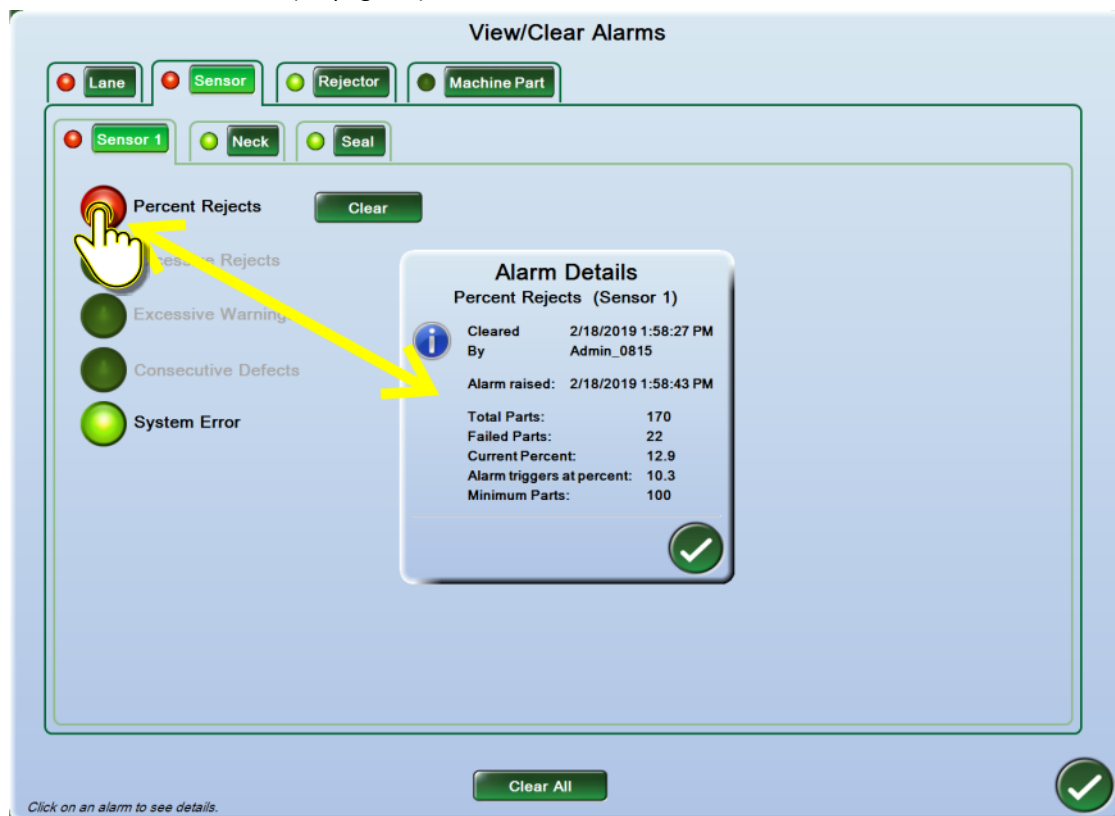

Select the **Clear** button to clear a single alarm, or the **Clear All** button to clear all alarms, including alarms in other tabs.

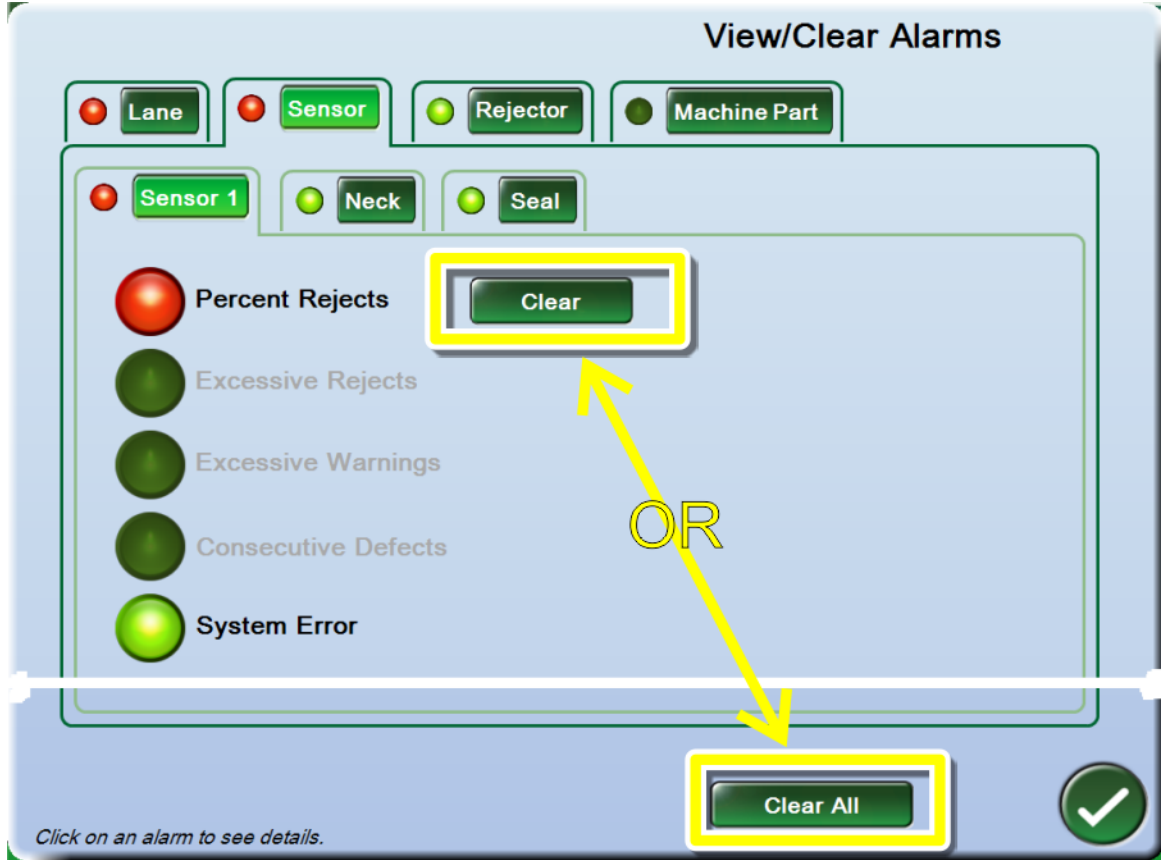

## System Alarms - Description and Configuration

The system alarms are the UPS (uninterruptible power supply) and CPU temperature alarms. You can configure the UPS shut down time.

These are only shown in the **System Overview** and will not show up as flashing lane buttons, or on any light tree, and will not sound a horn.

Alarm	Description	Action
UPS	Battery is dead.	Replace battery Automatically resets
	Or: Plant power is lost and the UPS shutdown time is exceeded. The Intellispec shuts down.	If plant power is restored before the Intellispec shuts down, then the alarm is automatically cleared. Otherwise, restart the system.
Over temperature	CPU temperature exceeds highest recommended operating temperature. The Intellispec system shuts down. You must wait till the processor cools before resuming operation.	

To get to this menu: select Home  | Alarms .

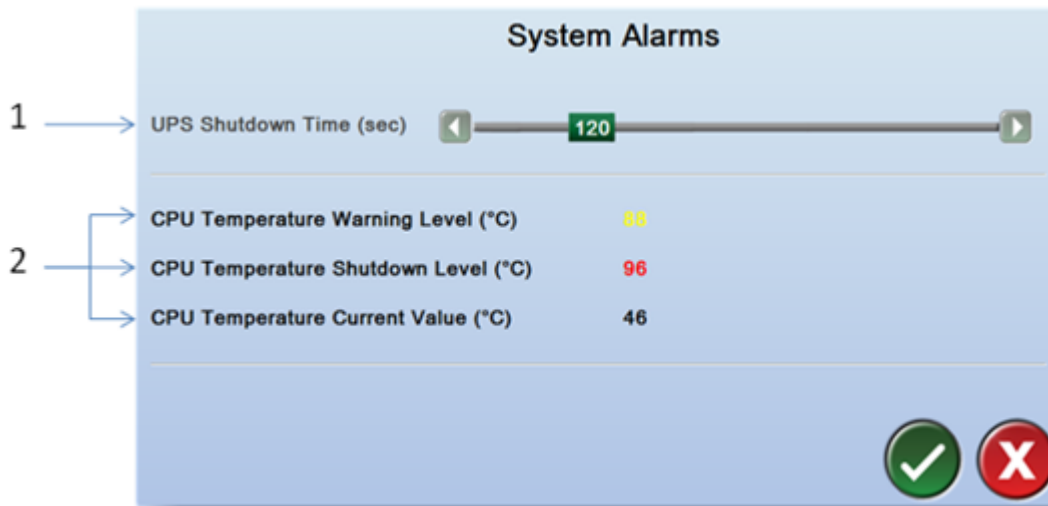

1) **UPS Shutdown Time** – The number of seconds that the UPS will maintain power to the system if AC power has been lost. The Intellispec system shuts down after this time period. This allows for a normal Windows shutdown.

2) **CPU Temperature** – If a multiple core computer is used, the highest temperature is displayed. If the shutdown CPU temperature is reached, the Intellispec system shuts down.

## Lane Alarms - Brief Description

The Lane Alarms affect the hardware associated with one lane. A lane usually refers to one production line, and can contain multiple sensors.

Alarm	Description	Action	Light Tree <sup>2</sup>
Percent Defects <sup>1</sup>	Percentage of defects exceeds the set limit.	Check the production line to see what might be creating too many bad parts Reset alarm on screen	 Red
Offline <sup>1</sup>	Lane goes offline	Automatically resets	 Green = system is online  Red = system is offline
Chute Full <sup>1</sup>	Reject chute is full	Clear chute Reset alarm on screen	 Red
Power Status <sup>1</sup>	Lane AC Power is lost	Automatically resets Troubleshoot: Check that the inspection module power switch is on. Check +24V supply.	 Red = AC power is lost  Blue = power is OK
Good Parts <sup>1</sup>	Used as a part counter. When specified number of parts is reached, then alarm is triggered.	Replace the box with counted parts with an empty box, then clear alarm. Reset alarm on screen	 Red
System Error <sup>1</sup>	Part tracker or other internal system errors	Depends on specific alarm (see details for System Error Alarm) Reset alarm on screen	 Red Red Flashing for Part Tracker Lost Communication

<sup>1</sup> If you want to connect an external monitoring device such as a PLC, an optional Extended I/O board is required for each lane.

<sup>2</sup> The light tree displays this color for the Duration if Visual Enabled.

## Sensor Alarms - Brief Description

Sensor alarms are configured for each sensor (camera or other sensor).



Alarm	Description	Action	Light Tree <sup>2</sup>
Percent Rejects <sup>1</sup>	<b>Percent Rejects</b> - This alarm is triggered when the <b>Trigger [%]</b> is exceeded. It will remain triggered until you clear the alarm.	Check the production line to see what might be creating too many bad parts Reset alarm on screen	 Red
Excessive Rejects <sup>1</sup>	<b>Excessive Rejects</b> - This alarm is triggered when <b>Trigger [%]</b> of the last <b>Sample Size</b> parts have been found defective. It will remain triggered until you clear the alarm.	Check the production line to see what might be creating too many bad parts Reset alarm on screen	 Red
Excessive Warnings <sup>1</sup>	<b>Excessive Warnings</b> - This alarm is triggered when <b>Trigger [%]</b> of the last <b>Sample Size</b> parts have been found with a warning status. It will remain triggered until you clear the alarm. Warnings are enabled in the Retro-Spec Options when you are editing an inspection. They can also be enabled in Lane Setup   Select Features.	Check the production line to see what might be creating too many bad parts Reset alarm on screen	 Amber
Consecutive Defects <sup>1</sup>	<b>Consecutive Defects</b> - This alarm is triggered when <b>Consecutive Triggers</b> has been exceeded [the sensor had too many consecutive defects]. It will remain triggered until you clear the alarm.	Check the production line to see what might be creating too many bad parts Reset alarm on screen	 Red
Mass Lighting	<b>Mass Lighting</b> - This alarm is triggered when the lighting threshold falls below a minimum level.	Clean the mass sensors and emitters Reset alarm on screen	none
System Error <sup>1</sup>	Missed part, missed acquisition, missed result, or other internal error	Reset alarm on screen	 Red

<sup>1</sup> If you want to connect an external monitoring device such as a PLC, an optional Extended I/O board is required for each lane.

<sup>2</sup> The light tree displays this color for the Duration if Visual Enabled.

## Rejector Alarms - Brief Description

Rejector Alarms are triggered when a part did not get rejected as expected.

Alarm	Description	Action	Light Tree <sup>2</sup>
Jam at Reject Confirm <sup>1</sup>	The reject confirm path has been blocked too long. Works with Reject Confirm.	Remove jammed parts at the rejecter, then clear alarm. Reset alarm on screen	 Red
Missed Reject <sup>1</sup>	System missed rejecting a part. Works with Reject Confirm.	Reset alarm on screen	 Red
Missed Result <sup>1</sup>	The part reached the rejecter before the part was fully inspected and the result was sent to the part tracker. That is, the inspections took too long to run.	If this occurs often, look at the inspection settings. It may be possible to use other settings to reduce inspection time. Reset alarm on screen	 Red





<sup>1</sup> If you want to connect an external monitoring device such as a PLC, an optional Extended I/O board is required for each lane.

<sup>2</sup> The light tree displays this color for the Duration if Visual Enabled.

## Machine Part Alarms - Brief Description

Machine Part alarms are the correlation-based alarms. They are visible only if your system has correlation sensors installed.

❖ *Note: for Machine Part Alarms, except Correlation Out of Range, statistics apply to each correlation value separately. That is, if one of 100 machine parts fails at 100 percent, the detected percentage is 100 percent while overall it would be 1 percent.*

Alarm	Description	Action	Light Tree <sup>2</sup>
Percent Rejects <sup>1</sup>	<b>Percent Rejects</b> - This alarm is triggered when the <b>Trigger [%]</b> is exceeded. It will remain triggered until you clear the alarm.	Check the production line to see what might be creating too many bad parts for this correlation value Reset alarm on screen	 Red
Excessive Rejects <sup>1</sup>	<b>Excessive Rejects</b> - This alarm is triggered when <b>Trigger [%]</b> of the last <b>Sample Size</b> parts have been found defective for a correlation value. It will remain triggered until you clear the alarm.	Check the production line to see what might be creating too many bad parts for this correlation value Reset alarm on screen	 Red
Excessive Warnings <sup>1</sup>	<b>Excessive Warnings</b> - This alarm is triggered when <b>Trigger [%]</b> of the last <b>Sample Size</b> parts for a correlation value have been found with a warning status. It will remain triggered until you clear the alarm. Warnings are enabled in the Retro-Spec Options when you are editing an inspection. They can also be enabled in Lane Setup   Select Features.	Check the production line to see what might be creating too many bad parts for this correlation value Reset alarm on screen	 Amber
Consecutive Defects <sup>1</sup>	<b>Consecutive Defects</b> - This alarm is triggered when <b>Consecutive Triggers</b> has been exceeded [the correlation value had too many consecutive defects]. It will remain triggered until you clear the alarm.	Check the production line to see what might be creating too many bad parts for this correlation value Reset alarm on screen	 Red
Correlation Out of Range	<b>Correlation Out of Range</b> - This alarm is triggered if the part tracker counts a machine part that was not configured.	Reset alarm on screen	 Red

<sup>1</sup> If you want to connect an external monitoring device such as a PLC, an optional Extended I/O board is required for each lane.

<sup>2</sup> The light tree displays this color for the Duration if Visual Enabled.

## Machine Part Alarms - View/Clear

From  | View/ Clear Alarms | Machine Part:

View/Clear Alarms

Lane
Sensor
Rejector
Machine Part

Cavity
Spindle
InFeed

● Percent Rejects

● Excessive Rejects Clear

● Excessive Warnings Clear

● Consecutive Defects

● Correlation Out Of Range

**Correlation Alarm Details**  
*InFeed*

2. Excessive Rejects ▼

Alarm triggers at percent: 2  
Sample Size: 100

Next Triggered Item ▲ ▼

1.	2.	3.	4.	Item	Parts	Failed	Failed %	When
●	●	●	●	1	100	4	4	15:50:37.669
●	●	●	●	2	100	4	4	15:50:37.813
●	●	●	●	3	100	3	3	15:50:35.522
●	●	●	●	15	100	4	4	15:50:36.937
●	●	●	●	16	100	4	4	15:50:37.057

Update ✓

Clicking on any statistics-based machine part alarm shows a details table breaking the alarm details down per correlation value (aka machine part item). The table lets you select any of the (enabled) alarms either by using the drop down or by clicking one of the columns 1., 2., 3., 4. (This may only be 1., 2., if only two alarms are enabled). When any machine part item is in alarm and not all machine parts can be displayed simultaneously, a “Next Triggered Item” navigator is shown to quickly find the item in alarm. The “Update” button allows re-reading details information (how many parts have currently been processed and how many failed; this is automatically done if an alarm is raised while in this view).

# Chapter 11

## Graphs and Image Displays

Several graphs are available on the user interface to help you view inspection trends. This section discusses the buttons on the right side of the screen in the Lane Overview and Sensor Overview modes.

### Trend Graphs



➤ **To view the Lane trend graphs:**

1. Select a lane (click a Lane n button).
2. Click a **Trend Graphs** button on the right side of the screen. The trend graph is displayed.

❖ *Note: There are two Trend Graphs buttons available. One is for the lane; the other is for the sensor. If you are viewing **Lane Overview** mode, then the trend graph in the upper screen is where you select the viewing options. The trend graphs in the lower screen follow the settings from the upper screen. In **Sensor Overview** mode, you can select viewing options separately within the upper and lower screens.*

For Trend Graphs, you can select which data to display. Select from the Series drop-down menu.

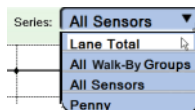

#### Lane Total

Statistics are averaged for all sensors within the lane.

#### All Walk-By Groups

Statistics for inspection groups. These groups are defined in the Walk By Graphic setup, and pertain to a specific area of a part.

#### All Sensors

Statistics for each sensor.

#### Individual Sensors [names vary]

Statistics for only the selected sensor.

Note: A key (to explain color-coding and data point shape) is displayed to the right of the graph for All Walk-By Groups and All Sensors.

### Machine Part Graphs

Machine Part Graphs are available when you have the Correlation option installed. Machine Parts Graphs display defect information for each machine part. Below is a list of possible combinations for Defect % and Defect Count.

H-axis	V-axis	Series
Defect %	Machine Parts	Lane Total All Sensors
Defect Count	Machine Parts	Lane Total All Sensors

An example graph is displayed below. It shows defects for a machine part type, and the number of defects correlated to each sensor.

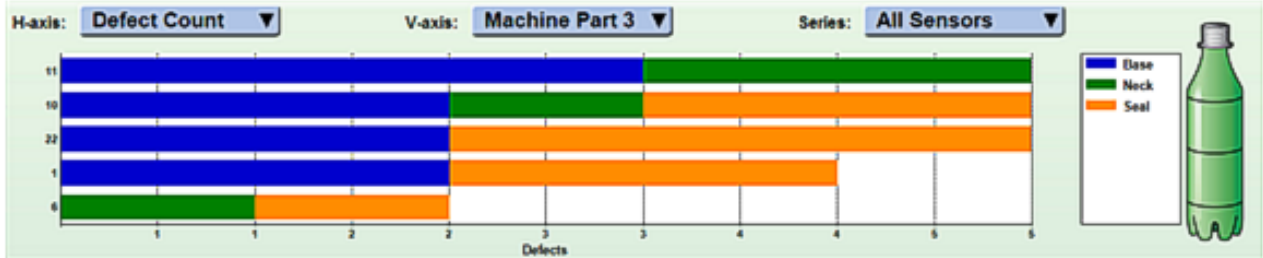

## Sort Data in Graphs

Change the order of the displayed data in the Trend Graphs or Machine Part Graphs (if configured).

- ❖ *Note: when you change sorting order, it affects the **Trend Graphs** or **Machine Part Graphs** in the upper and lower screens. Other graphs are not affected.*

To sort the graph data: Right-click over a graph | select Sort Method | select an option.

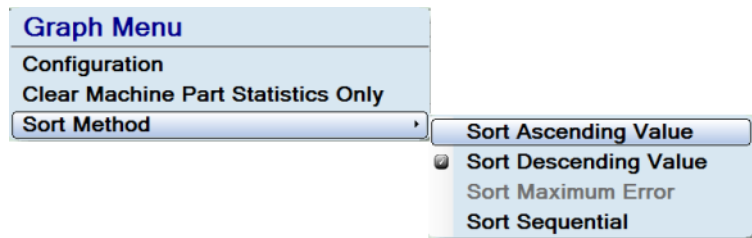

- **Sort Ascending Value** – Sort from low to high result. In the example below, the machine part with the highest number of defects is shown on the right side of the graph.

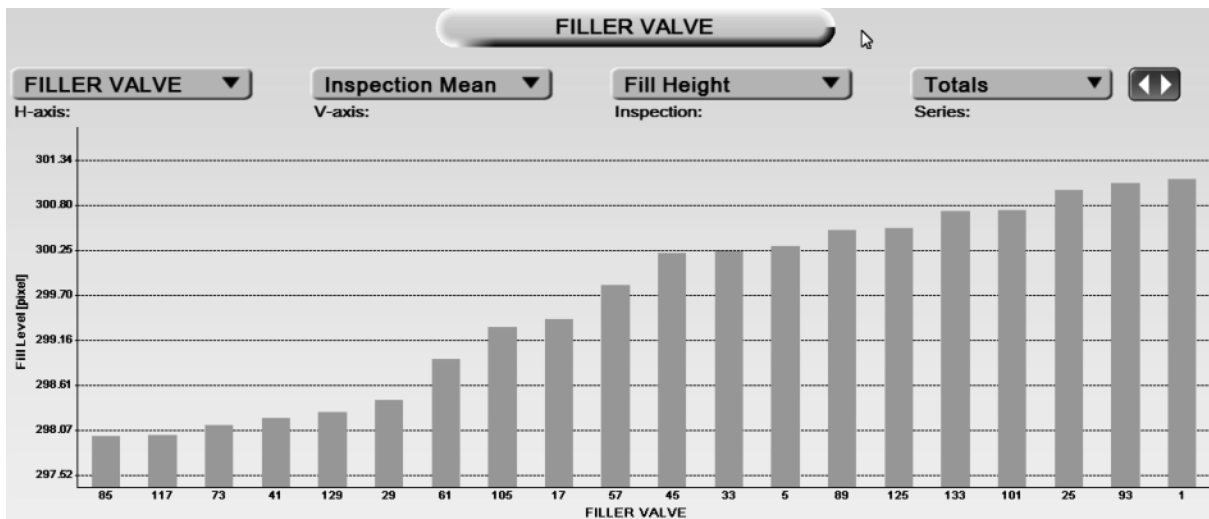

- **Sort Descending Value** – Sort from high to low result. In the example below, the machine part with the highest number of defects is shown on the left side of the graph.

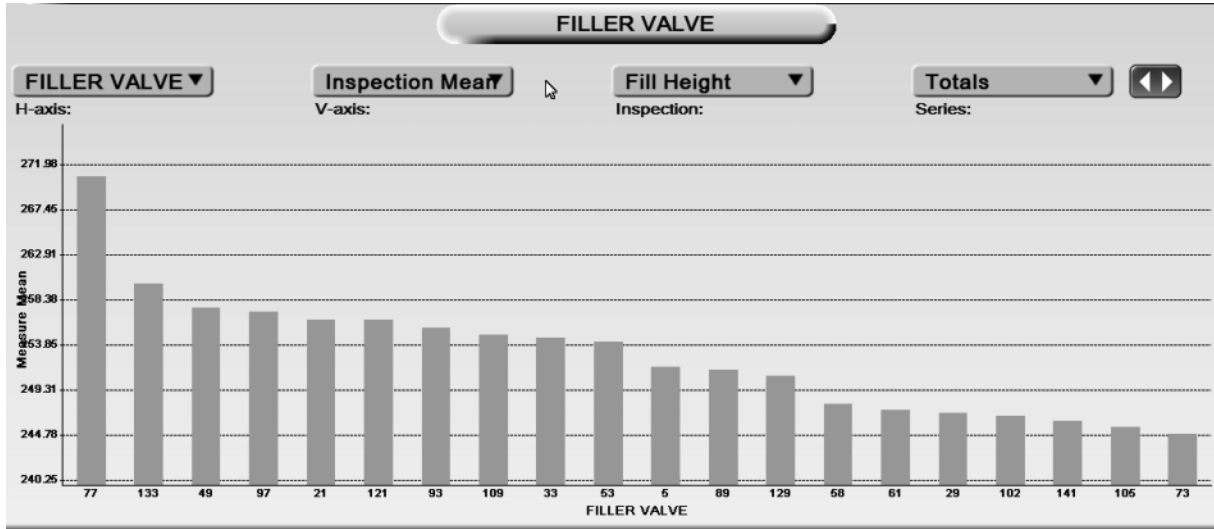

- **Sort Maximum Error** – [Available when "Record SPC Statistics" is enabled for an inspection, Totals is selected for the graph Series, and Inspection Mean is selected for V-Axis] Sort the data by machine part where the highest peak shows the furthest value from nominal, as an absolute value.

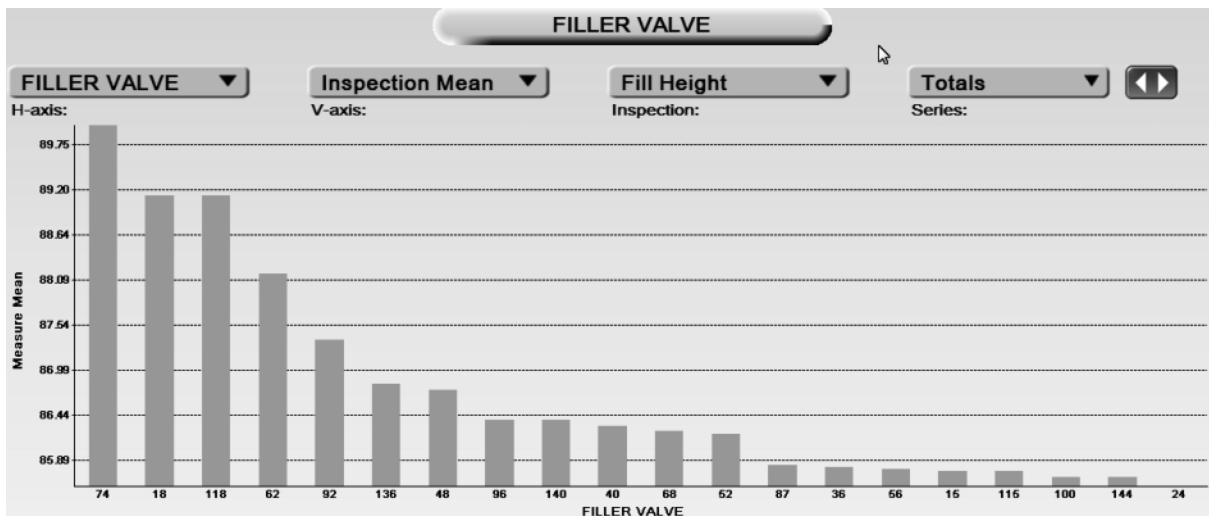

- **Sort Sequential** – Display an ordered list of machine parts.

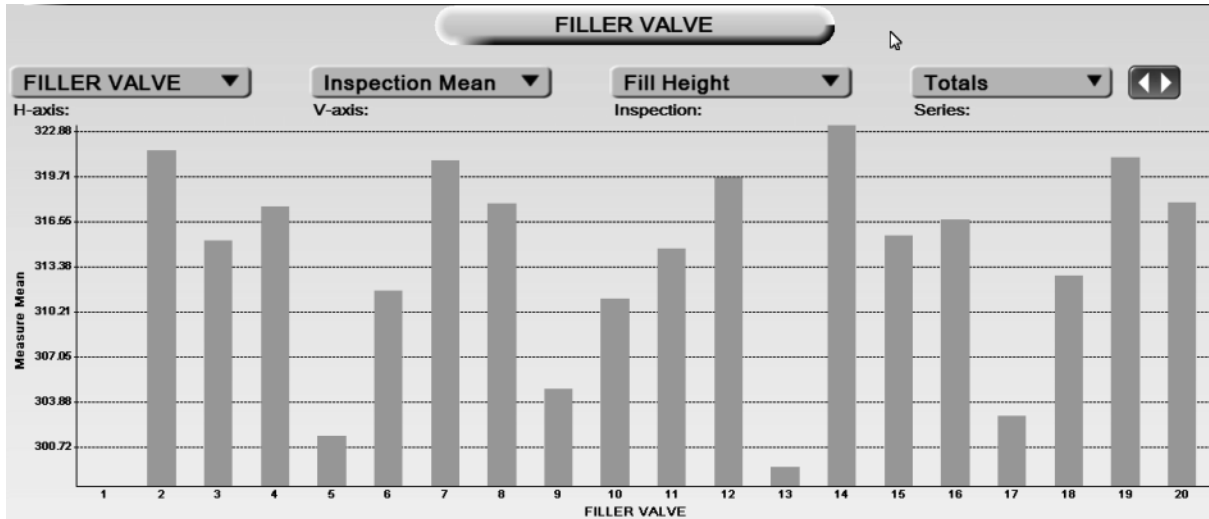

## Statistics Grid



The Statistics Grid displays information about each Sensor. There are two types of Statistics Grids: Lane and Sensor.

### Lane Statistics Grid

The Lane Statistics Grid (in Lane Overview mode) displays general information about each Sensor. It shows the Total number of parts run, Sensor, Defects, Defect %, Last N, and Last N %.

Sensor	Total	Defects	Defect %	Last N	Last N %
Rivet	56748	56748	100.000	953	95.300
Panel	56748	56748	100.000	953	95.300

### Sensor Statistics Grid

This grid is available when you display Sensor information. It shows specific information for each sensor, including Inspection, Total number of parts run, Defects, Defect %, Last N, and Last N %.

Inspection	Total	Defects	Defect %	Last N	Last N %
Pattern Match	56748	56748	100.000	953	95.300
Radial Edge	56748	0	0.000	0	0.000
Ring	56748	0	0.000	0	0.000
Ring	56748	0	0.000	0	0.000

❖ *Note: you can **configure** (see "**Statistics Grid options**" on page 87) the statistics display. Your system may not display all of the above-mentioned items.*

### Sorting order

To sort any column in ascending or descending order, select the button at the top of the column. Select it again to toggle to the opposite order. Right-click to clear sorting in the statistics grid.

Inspection	Total	Defects	Defect %	Last N	Last N %
Pattern Match	56748	56748	100.000	953	95.300
Radial Edge	56748	0	0.000	0	0.000
Ring	56748	0	0.000	0	0.000
Ring	56748	0	0.000	0	0.000

## Statistics Grid options

These settings are applied to all statistics grids, whether in the Lane Overview or Sensor Overview mode. Right-click over any statistics grid to see the options. These are explained below.

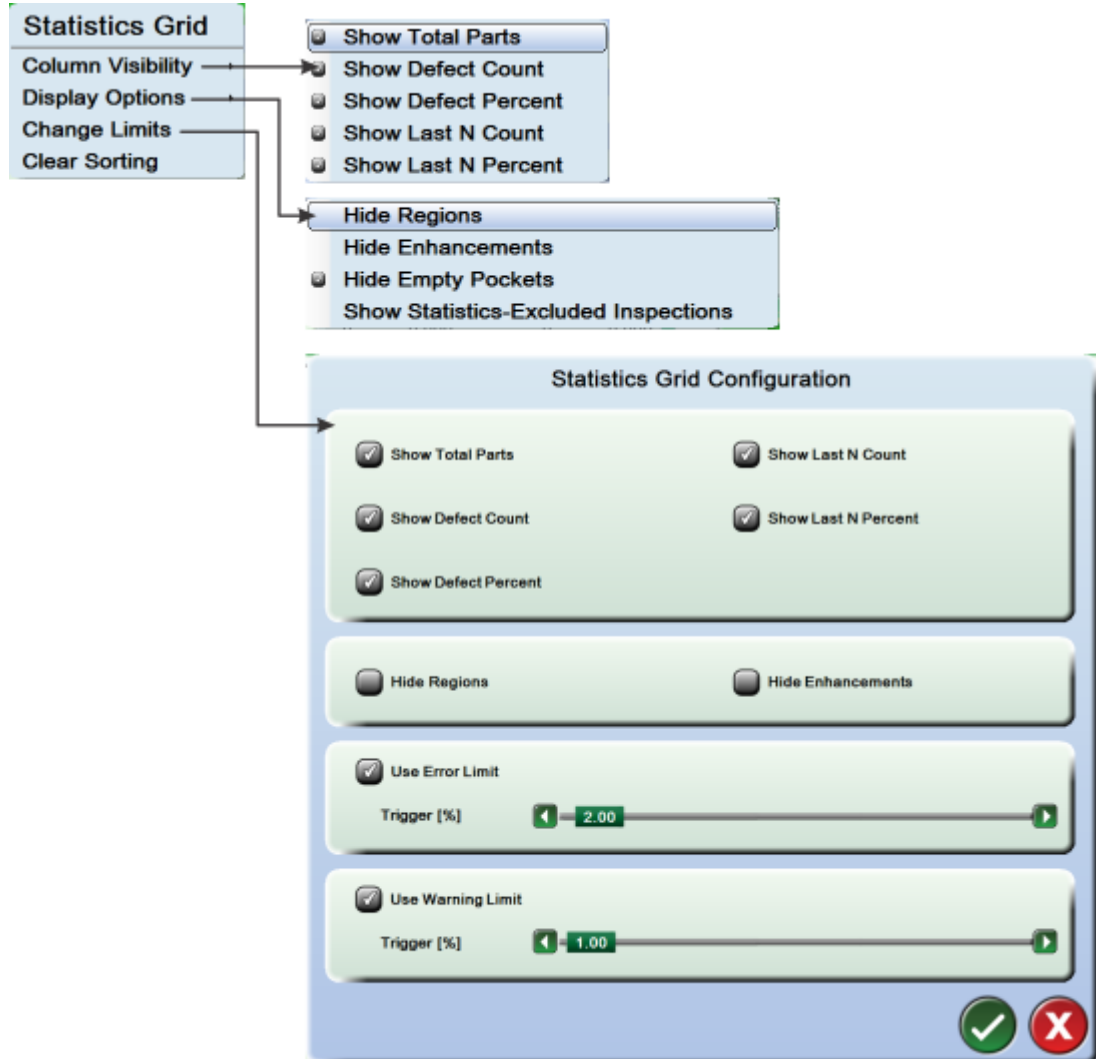

### Column Visibility

The number of columns in the grid.

### Display Options

The number of rows in the grid. This only affects the statistics grids in the Sensor Overview level.

### Hide Regions

Hide regions such as Ring, Adaptive, or Rectangle from the grid.

### Hide Enhancement

Hide enhancements such as Clipping, Stretch Grayshades, or Power Filter.

### Hide Empty Pockets and Show Statistics-Excluded inspections

Show or hide Empty Pocket or Statistics-Excluded inspections.

### Change Limits

Change the number of columns and rows of the grids in the first two sections of the menu. These are the same as Column Visibility and Display Options.

### Use Error Limit

Causes the **Defect %** and **Last N %** columns to display in red if the trigger percentage is exceeded. This allows you to see these statistics from a distance.

### Use Warning Limit

Causes the **Defect %** and **Last N %** columns to display in yellow if the trigger percentage is exceeded. This allows you to see these statistics from a distance.

### Clear Sorting

Puts the sorting order back to the default setting.

---

## Reject Images

### Reject Images

Reject Images are images from the last 100 defects from a sensor (or all sensors for Lane Overview mode). Select a **Reject Images** button. Note: there are buttons for **Lane** and **Sensor** levels.

**Lane Reject Images** show failed images from different sensors.

**Sensor Reject Images** show failed images from that sensor only.

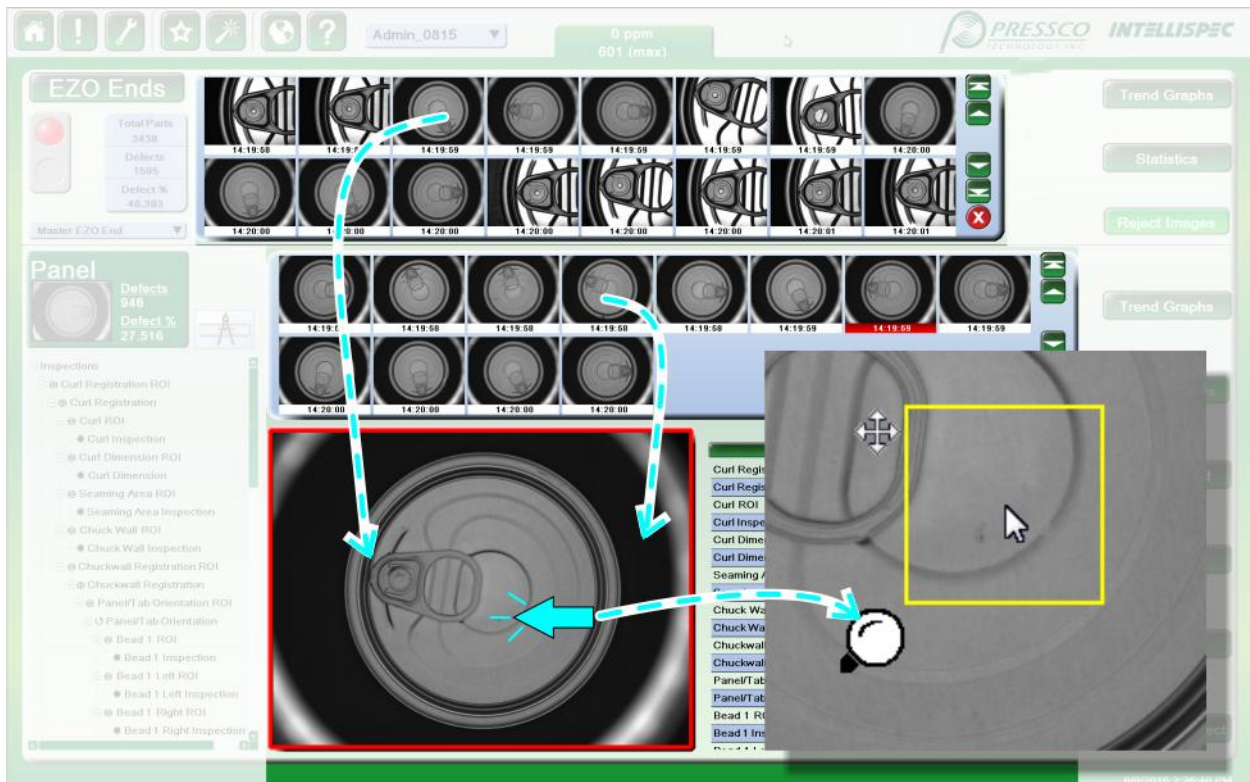

## Inspections graph



Select the **Inspections** button to display the Defect Count or Defect % for the selected sensor. It displays the failed inspections in descending order of failure. The example below shows the graphs in both Lane Overview and Sensor Overview modes.

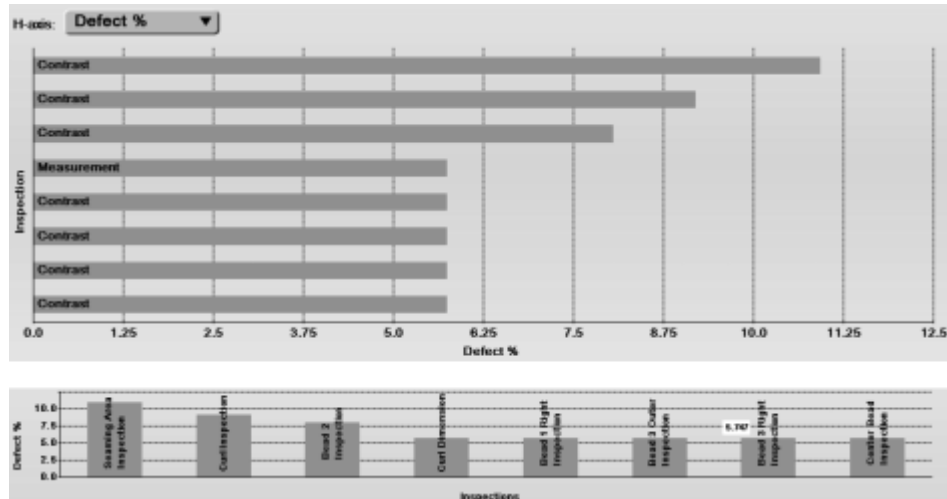

When you right-click over the graph, you can choose to view or hide Empty Pocket or Statistics-Excluded inspections.

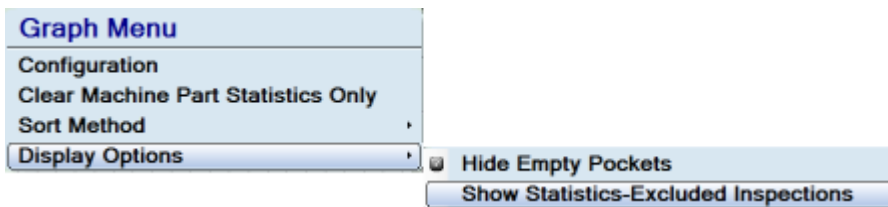

## Walk By Graphic

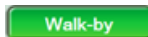

This is a graphic representation of a part so that you can quickly identify which area of the part is failing. It is called Walk By because you can quickly walk by the Intellispec and look at the graphic to determine the status of inspection:

- **Green** = passing parts
- **Yellow** = warning. The spoilage rate is approaching, but has not yet reached a critical level. You can make changes to the manufacturing process before the failure rate gets too high.
- **Red** = failing parts

Set up warning or failure limits in Walk By Setup.

There are two Walk By Graphics:

- A **small** Walk By Graphic is displayed in System Overview, Lane Overview, and Sensor Overview modes
- A **large** Walk By Graphic can be displayed in Lane Overview mode

➤ **To see the large Walk By Graphic:**

1. Select a Lane button.

2.  Select the Walk By button on the right side of the screen.

The large Walk By Graphic displays the group names, pointing to the appropriate areas on the part. It also displays the defect percentage for each of those groups, from inspection results.

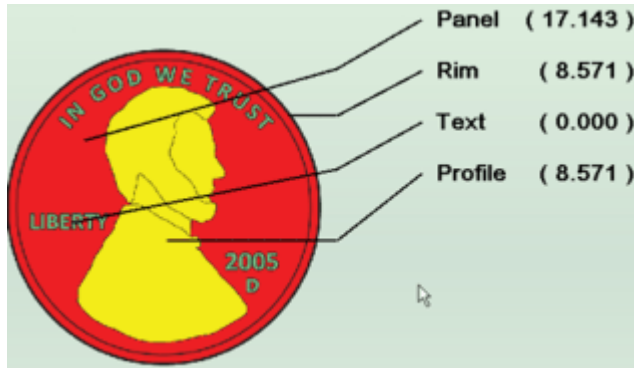

## Using the Walk By Graphic

View inspection information by selecting on the areas of the graphic. The example below shows:

- The Panel group was selected - all the inspections for Panel are displayed in the table
- The Panel area in the Walk By Graphic is red - The average defect % for the group of inspections exceeds the failure limit from the Walk By setup

Inspection	Total	Defects	Defect %	Last N	Last N %
Polygon	312615	26794	8.571	78	7.800
Contrast	312615	44658	14.285	130	13.000
Polygon	312615	26794	8.571	78	7.800
Contrast	312616	35727	11.428	105	10.500
Polygon	312616	26795	8.571	79	7.900
Contrast	312616	44659	14.286	131	13.100

Double-click an inspection from the table to open and edit that inspection. Note: Some menu items are only available to advanced level users.

## Freeze on Defect

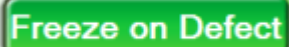





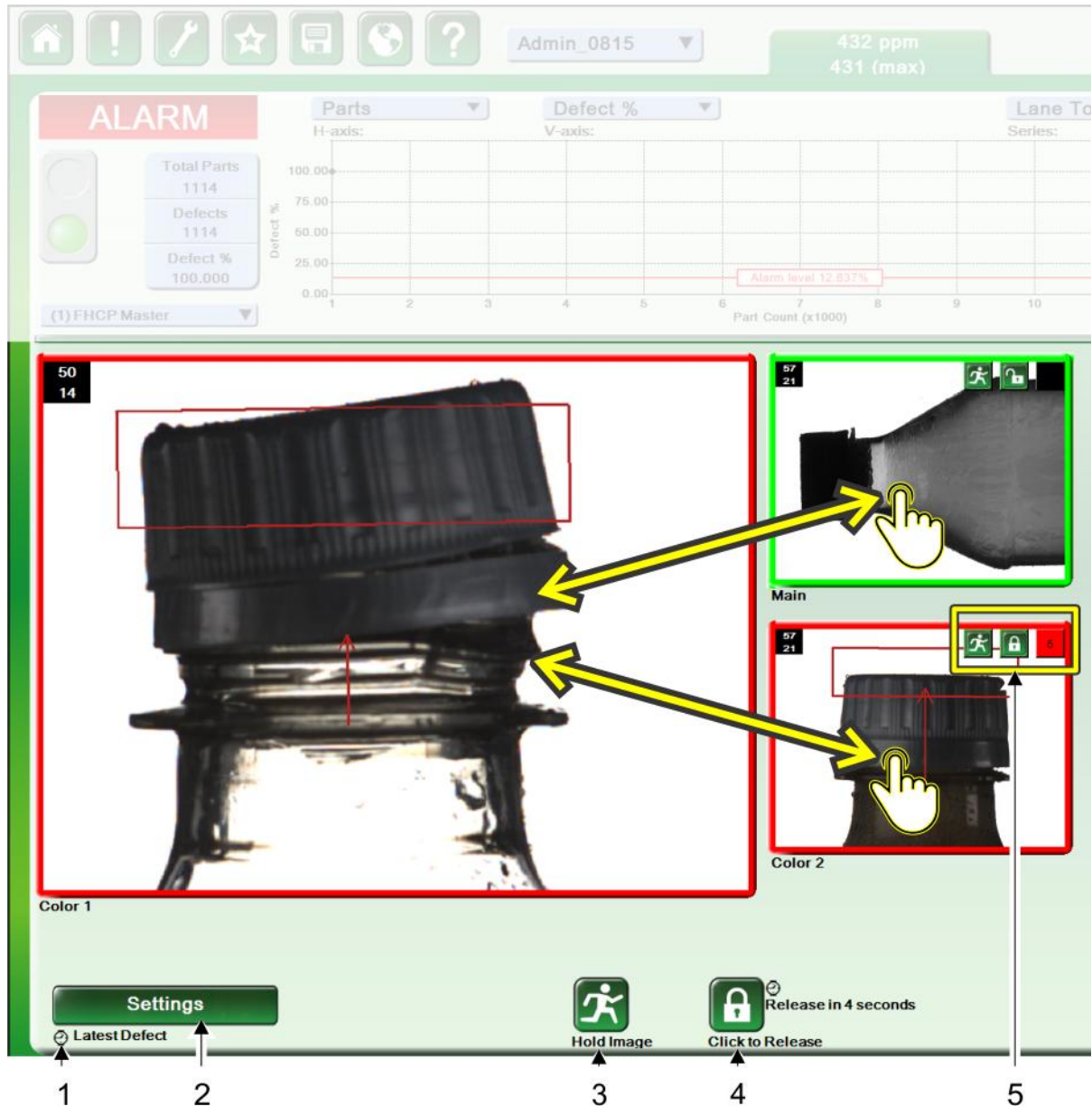

Automatically freeze an image when a lane is online. Freeze on Defect has two views: **Multi Sensor View** and **Single Sensor View**.

Note: the information in this topic applies to software versions 5.5.029, 5.6.008, 5.7.005, 6.0.016 and higher.

## Multi Sensor View

This is accessed from **Lane Overview Screen**.



- 1)  = Optional Timed Release feature
- 2) Go to **Freeze on Defect Setup menu** (on page 93)
- 3)  = Hold an image.  = Held image.
- 4)  = Locked image. Select this button to release an image.  = Unlocked image.
- 5) These symbols appear only on the smaller images, when **Side-by-Side Locked Images = Latest Sensor Image** in the Settings menu (**Freeze on Defect Setup menu** (on page 93)). The number in the upper right corner of the small image is the countdown timer (when Timed Release is used). The large image does not show these buttons; holding the image is controlled by the buttons at the bottom of the screen. Right-click over any image to use the **Freeze on Defect Options menu** (on page 95)

## Pinned Image

In Multiple Sensor View, a view can be pinned to the large image when **Automatically switch to the latest locked image** is enabled. This allows you to work with the image for 10 seconds before it gets replaced by another image. When you select one of the smaller images, that image gets moved to the large image, and is pinned there temporarily. A push pin icon is displayed below the large image.

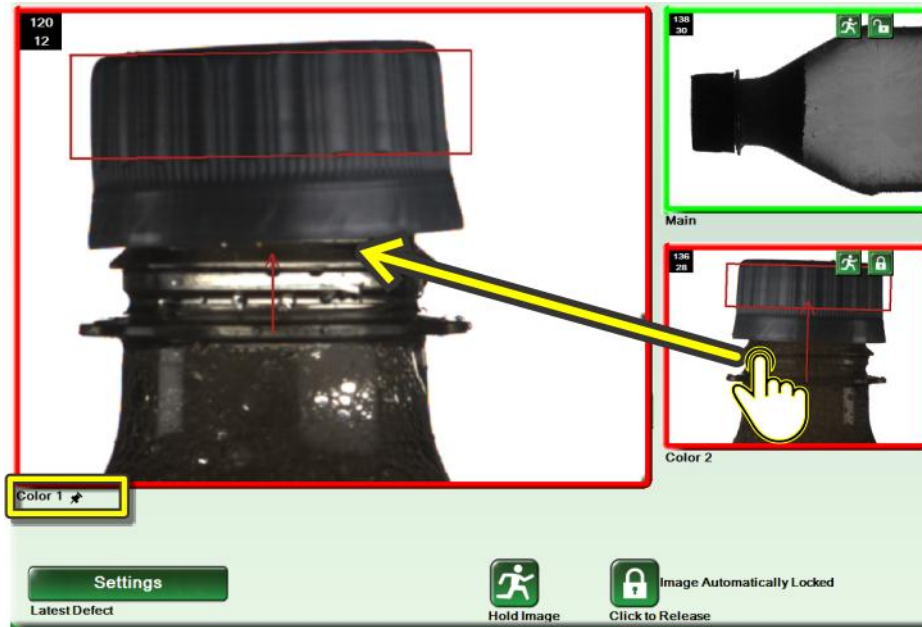

- **To exit Freeze on Defect:**
  - Select another button on the right side of the screen (example: Trend Graphs).

### Single Sensor View

Enter this view from the **Sensor Overview Screen**. Select the inspection to freeze from the inspection tree.

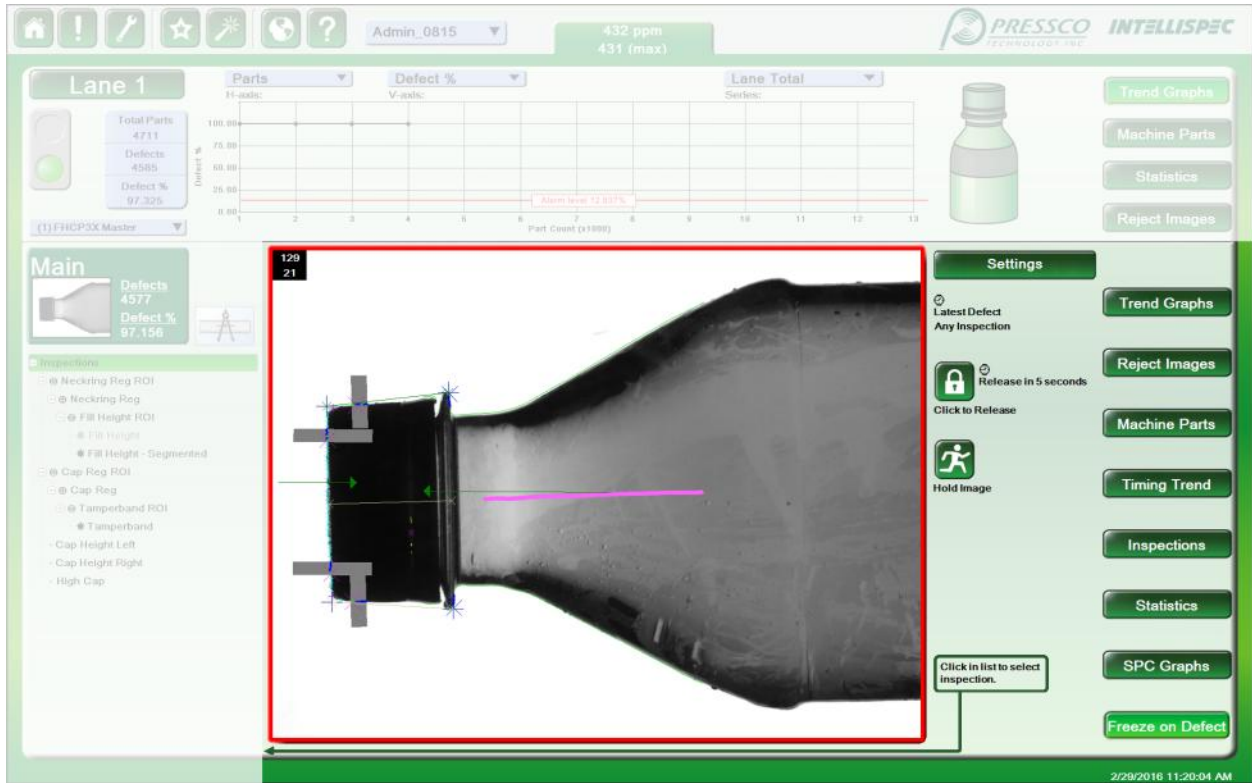

### Freeze on Defect Setup menu



Select the **Settings** button from Freeze on Defect mode. Menu options change based on where you entered from.

Note: the information in this topic applies to software versions 5.5.029, 5.6.008, 5.7.005, 6.0.016 and higher.

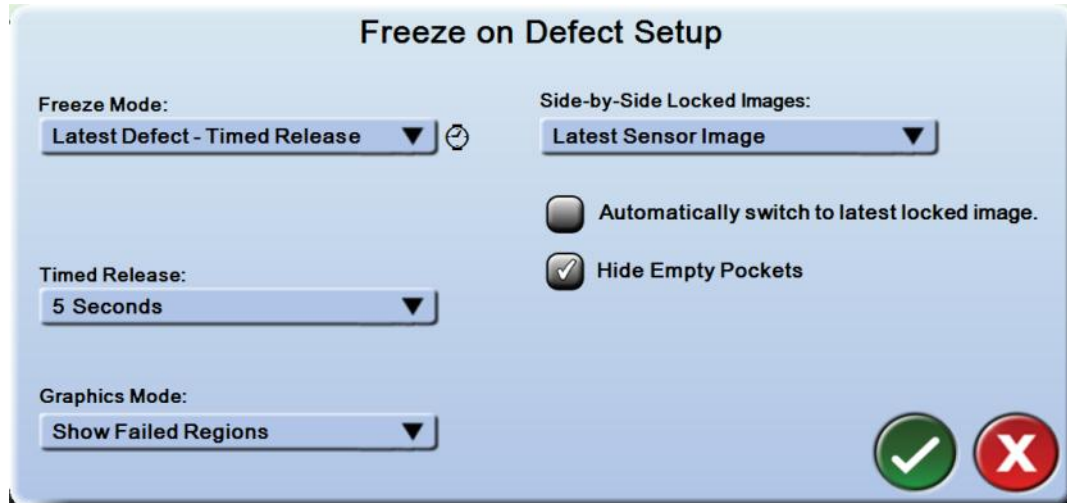

## Freeze Mode

### Manual Lock Only

Do not automatically hold an image. Images will be updated continuously, except if you select the Hold Part button. 

### Latest Defect

Freeze the last rejected part. Each subsequent failing part will freeze until another part fails.

### Latest Defect - Timed Release

Hold the last defective image for a number of seconds (set by **Timed Release**). If another defect occurs during the countdown, that image is frozen and the Timed Release countdown resets.

### First Defect

Freeze the image of the first defective part after going online. The image freezes until you release it (select ) or change Freeze Mode.

### First Good

Freeze the image of the first good part after going online. The image freezes until you release it (select ) or change Freeze Mode.

### Machine Part

Freeze the next part image correlated to the selected machine part. It freezes until the next correlated image becomes available and is replaced by the new image.

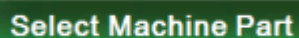
 **Select Machine Part**

Use the **Select Machine Part** button to select the machine part.

### Machine Part - Timed Release

Freeze the next part image correlated to the selected machine part. It remains on screen for the specified time, or until the next correlated image becomes available, whichever comes first. Use the **Timed Release** settings to set the display time.

### Timed Release

Set the display time. When the time expires, a new image is displayed.

### Graphics Mode

[For software versions 5.3.035, 5.5.016, 5.6.002, 6.0.002 and higher] Select which inspection graphics to display.

For software earlier than the above-mentioned versions, the only mode that works correctly is Show No Graphics.

### Hide Empty Pockets

If enabled: If an inspection detected an Empty Pocket, then that blank image will not be displayed. The following only apply if you are in **Multi Sensor View**.

### Side-by-Side Locked Images

**Same Part** - The images displayed are all the same part.

**Latest Sensor Image** - Displays the last inspected images. If your cameras are located far apart, the images may be different parts. This mode is usually used when your cameras are close together, such as in a BNS application. If your system uses Machine Part Correlation, you can "Show Correlation Values in Images," so that you can see which image is associated with each machine part.

### Automatically Switch to Latest Locked

This switches the image that most recently met the freeze frame conditions to the large image.

---

## Freeze on Defect Options menu

Select or right-click over one of the images from Freeze on Defect mode to see the menu.

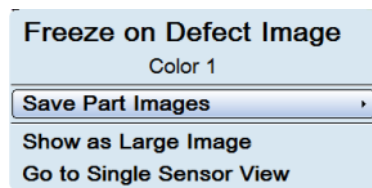

### Show as Large Image

[Available from **Multi Sensor View**, when you right-click over a smaller image] Display the current image as the large image.

### Go to Single Sensor View

Go back to Sensor Overview mode and display the Reject Images screen for the selected sensor.

---

## Saving Images

There are a number of ways to save an image within the Intellispec system. Images can be saved whether the lane is online or offline, except the option: "Saving Images Automatically" - that option allows you to save information while the lane is online.

**Save any image:** In most parts of the system, right-click over any image to save it. A Save Image menu item will be displayed. Select the desired type of image, and save it. When the system asks you where to save it, use the disk icon to browse to a location. If you are using a USB device, insert the device and browse to it. This is useful to save images to include with a **Support Package**.

More information about how to save images from different locations can be found through the links below:

***Saving Images Through the Sensor Menu*** (see "***Save Images Through the Sensor Menu***" on page 96)

***Saving Images Automatically*** (see "***Auto-Save Images***" on page 96)

***Saving Reject Images*** (see "***Save Reject Images***" on page 97)

## Save Images Through the Sensor Menu

Save a set of images from one sensor (up to 100 images). You can save images whether the lane is online or offline. Right-click to see the menus.

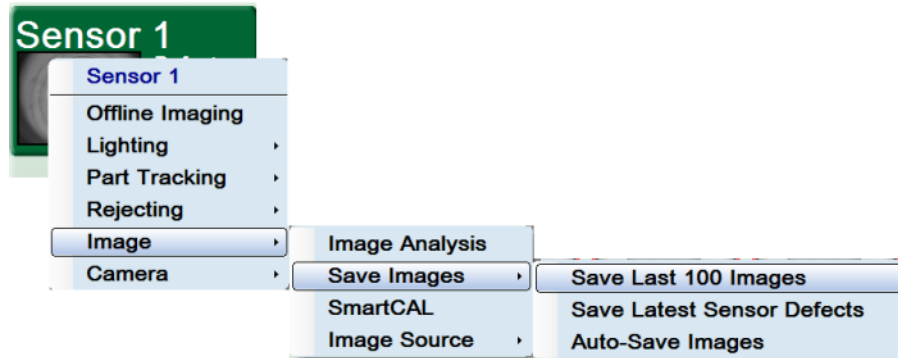

### Save Last 100 Images

Save the last 100 images captured by the current sensor.

### Save Latest Sensor Defects

Save the latest defect images shown in the Reject Images thumbnails, up to 100 images.

*Auto-Save Images* (on page 96)

## Auto-Save Images

Save up to 1000 images from one sensor when the lane is online. To get to this menu: Right-click a sensor button | **Images** | **Save Images** | **Auto-Save Images**.

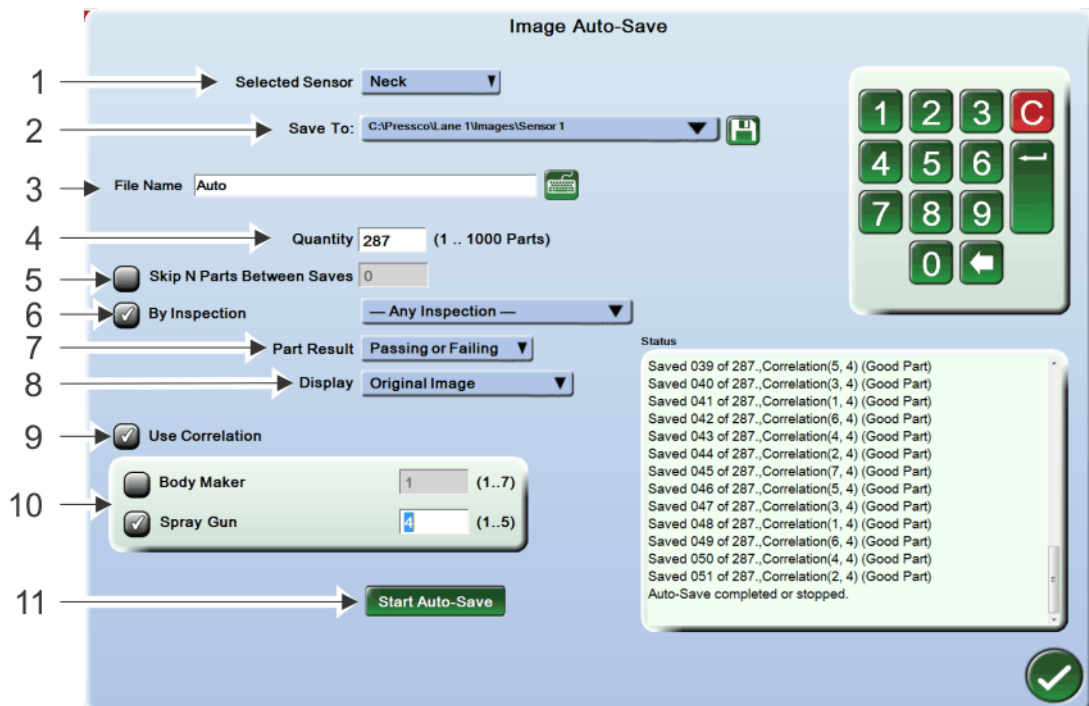

1) **Selected Sensor** - Select one or all sensors.

2) **Save To** - Select the location. To change the location, select the disk icon  and browse to the desired location.

- 3) **File Name** - Create a file name, descriptive of the part you are inspecting. The system automatically adds numbers and letters to the name. Example: "Auto0001\_S1\_P.bmp." [0001] = image 1. [S1] = Sensor 1. [P] = part passed. [F] = part failed.
- 4) **Quantity** - Quantity of images to auto-save, up to 1000.
- 5) **Skip N Parts Between Saves** - Check the box if you do not want to save consecutive images. Enter the number [N] of parts to skip between saved images.
- 6) **By Inspection** - Only available when you have one sensor selected [in item 1]. Save images related to an inspection. Use the drop-down menu to select the inspection from the current part program.
- 7) **Part Result** - Save images that pass or fail inspection, or both. When images are saved, the file name contains [P] for passing or [F] for failing.
- 8) **Display** - Save the original image from the camera, or the image after centering, or the image after centering and orientation.
- 9) **Use Correlation** - [available if correlation is installed] Save images correlated to specific machine parts.
- 10) **Machine parts** - [available if correlation is installed] Select the machine part(s) to save images from. Also enter a machine part number in the box provided.
- 11) **Start Auto-Save** - Select **Start Auto-Save** to start saving images. Select **Stop Auto-Save** to stop the process. The lane must be online to collect images.

## Save Reject Images

Save up to 100 (\*.bmp) images from defective parts. The lane can be online or offline.

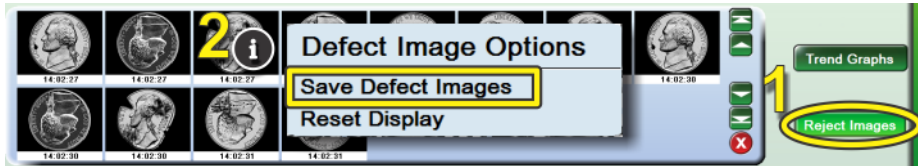

### Reset Display

Resets the reject image display to show all failed parts, instead of images from only one part or one inspection.

## Take Screen Shot

Capture an Intellispec screen image. This is different from saving individual part images through the **Save Image** (see "**Save Images Through the Sensor Menu**" on page 96) function. A screen shot is useful to illustrate a problem to technical support, or to capture settings for future setup.

### ➤ To capture the current full Intellispec screen:

1. Select the Star button  | Take Screen Shot. An onscreen keyboard is displayed with a default image name.
2. Re-name the screen shot if desired.
3. Select OK to save the image. The image is saved as a Portable Network Graphic (.png) file to C:\Pressco\DataExport\ScreenShots.



# Chapter 12



## Tools menu

This section covers the Tools menus that occur throughout the Intellispec system. The Tools menu has relevant tools for the following screens:

- System Overview screen
- **Lane Overview screen** (see "**Tools menu - Lane Overview and Sensor Overview Screens**" on page 100)
- Sensor Overview screen

---

### Tools menu - System Overview Screen

To get to this menu: Select the Home button  | Tools .

❖ *Note: Some menu items are only available to advanced level users.*

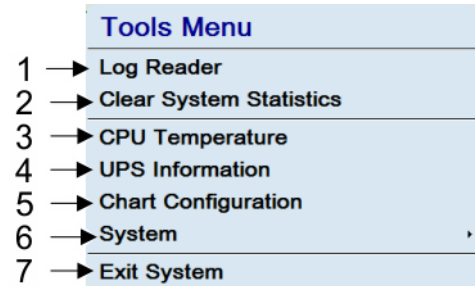

- 1) **Log Reader** - Open the Intellispec log
- 2) **Clear System Statistics** – Clear the entire system statistics (all Lanes)
- 3) **CPU Temperature** – If a multiple core computer is used, the highest temperature is displayed. If the shutdown CPU temperature is reached, the Intellispec system shuts down.
- 4) **UPS Information** – Display Uninterruptible Power Supply (UPS) information and settings
- 5) **Chart Configuration** – Choose the Trend Graph type and the number of points for the chart in the System Overview Screen
- not shown) - **Defect Writing** - [Only if Defect Database option is installed and enabled] Enable or disable defect recording for multiple lanes.
- 6) **System** - Set system date and time or set up a printer
- 7) **Exit System** – Shut down Intellispec software

---

### Log Reader

The log reader displays the Intellispec event history including:

- User log in and log out information
- Part program changes. Note: detailed part program changes are found in the Part Program Change Log
- Alarms, when triggered and cleared
- System errors
- System starting information
- Lane online/ offline history
- Lighting changes

Text files of the logs are stored at: C:\Pressco\Logs.

To get to this menu: select Home  | Tools  | Log Reader.

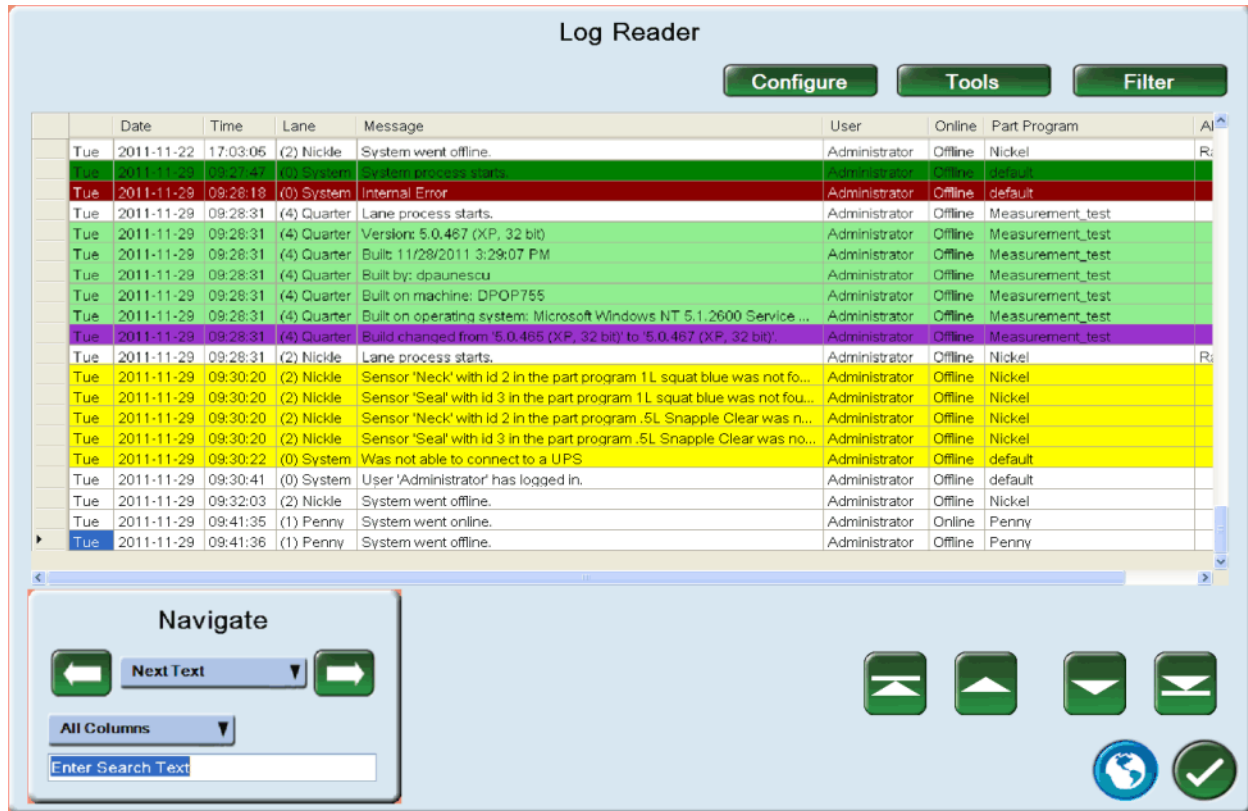

	Date	Time	Lane	Message	User	Online	Part Program
Tue	2011-11-22	17:03:05	(2) Nickle	System went offline.	Administrator	Offline	Nickel
Tue	2011-11-29	09:28:18	(0) System	System process start.	Administrator	Online	default
Tue	2011-11-29	09:28:18	(0) System	Internal Error	Administrator	Offline	default
Tue	2011-11-29	09:28:31	(4) Quarter	Lane process starts.	Administrator	Offline	Measurement_test
Tue	2011-11-29	09:28:31	(4) Quarter	Version: 5.0.467 (XP, 32 bit)	Administrator	Offline	Measurement_test
Tue	2011-11-29	09:28:31	(4) Quarter	Built: 11/29/2011 3:29:07 PM	Administrator	Offline	Measurement_test
Tue	2011-11-29	09:28:31	(4) Quarter	Built by: dpaunescu	Administrator	Offline	Measurement_test
Tue	2011-11-29	09:28:31	(4) Quarter	Built on machine: DPOP755	Administrator	Offline	Measurement_test
Tue	2011-11-29	09:28:31	(4) Quarter	Built on operating system: Microsoft Windows NT 5.1.2600 Service...	Administrator	Offline	Measurement_test
Tue	2011-11-29	09:28:31	(4) Quarter	Build changed from '5.0.465 (XP, 32 bit)' to '5.0.467 (XP, 32 bit)'	Administrator	Offline	Measurement_test
Tue	2011-11-29	09:28:31	(2) Nickle	Lane process starts.	Administrator	Offline	Nickel
Tue	2011-11-29	09:30:20	(2) Nickle	Sensor 'Neck' with id 2 in the part program 1L squat blue was not fo...	Administrator	Offline	Nickel
Tue	2011-11-29	09:30:20	(2) Nickle	Sensor 'Seal' with id 3 in the part program 1L squat blue was not fou...	Administrator	Offline	Nickel
Tue	2011-11-29	09:30:20	(2) Nickle	Sensor 'Neck' with id 2 in the part program .5L Snapple Clear was n...	Administrator	Offline	Nickel
Tue	2011-11-29	09:30:20	(2) Nickle	Sensor 'Seal' with id 3 in the part program .5L Snapple Clear was no...	Administrator	Offline	Nickel
Tue	2011-11-29	09:30:22	(0) System	Was not able to connect to a UPS	Administrator	Offline	default
Tue	2011-11-29	09:30:41	(0) System	User 'Administrator' has logged in.	Administrator	Offline	default
Tue	2011-11-29	09:32:03	(2) Nickle	System went offline.	Administrator	Offline	Nickel
Tue	2011-11-29	09:41:35	(1) Penny	System went online.	Administrator	Online	Penny
Tue	2011-11-29	09:41:36	(1) Penny	System went offline.	Administrator	Offline	Penny

## Tools menu - Lane Overview and Sensor Overview Screens

From Lane or Sensor Overview mode, select Tools .

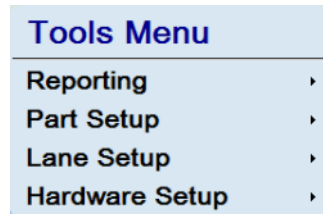

**Reporting** (on page 100)

**Part Setup** (on page 103)

**Lane Setup** (on page 104)

Hardware Setup

## Reporting

The Intellispec generates many different reports to provide inspection detail. Many of these reports can be transferred outside of the Intellispec.

❖ *Note: Some menu items are only available to advanced level users.*

To view reports: Select a Lane button **Lane n** | Tools  | Reporting.

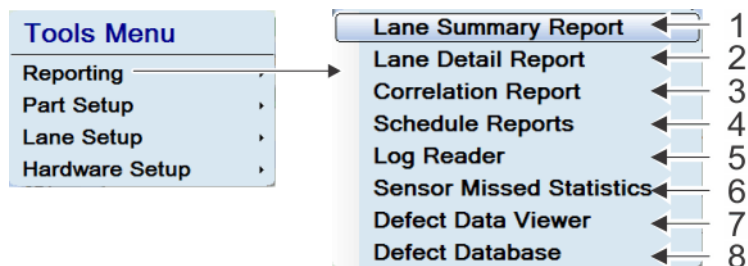

- 1) **Lane Summary Report** - summary of the statistics for the current lane
- 2) **Lane Detail Report** - lane and sensor defect statistics by inspection
- 3) **Correlation Report (on page 101)** - [if correlation is enabled] percentage of defects by machine part
- 4) Schedule Reports
- 5) **Log Reader** - Open the Intellispec log
- 6) **Sensor Missed Statistics** (on page 102) - the number of missed parts for the lane
- 7) **Defect Data Viewer** - [if enabled] view the images in the defect database
- 8) **Defect Database** - [if enabled] view the inspection data from the defect database

## Correlation Report

This report contains the percentage of defects by machine part, sorted from highest to lowest percentage of failure.

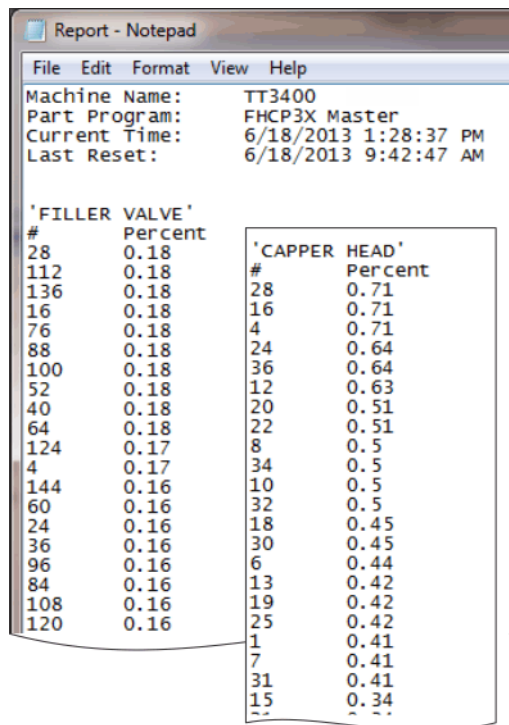

## Sensor Missed Statistics

Displays the number of missed parts and missed part tracking for the sensor. From Lane or Sensor Overview mode, select  | **Reporting** | **Sensor Missed Statistics**. This information is recorded in the **Log Reader** (on page 99).

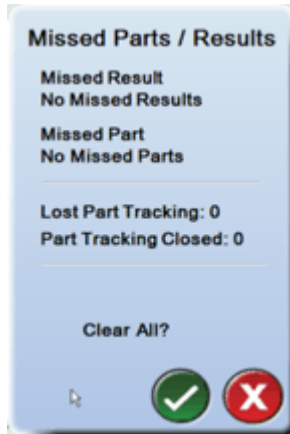

### Missed Results

This can occur if you set the Reject Delay Calibration incorrectly. Another cause could be kinks or intermittent connections to cables, or the inspection time for the lane is too long.

### Lost Part Tracking

This occurs if the system loses connection to the Part Tracker. You may be able to change the Missed Packets Exception threshold to prevent loss of connection.

## Error messages

### Part Tracker Exception

If you see an error "Part Tracker Exception" on the Intellispec screen, this means that power was lost to the Cluster Box or Part Tracker.

#### ➤ *To reset the part tracker board:*

Push the **Reset** button on the part tracker board. This is found inside the inspection module or Cluster Box.

### Lost Part Tracking

If you see a "Lost Part Tracking" message, possibly the power was lost to the Cluster Box or Part Tracker inside an inspection module. Reset the Part Tracker board as described above.

## Part Setup

The Part Setup menu provides access to lighting, part display options in charts, and part width calibration.

Some menu items are only available to advanced level users.

To get to this menu: From Lane Overview mode, select Tools  | **Part Setup**.

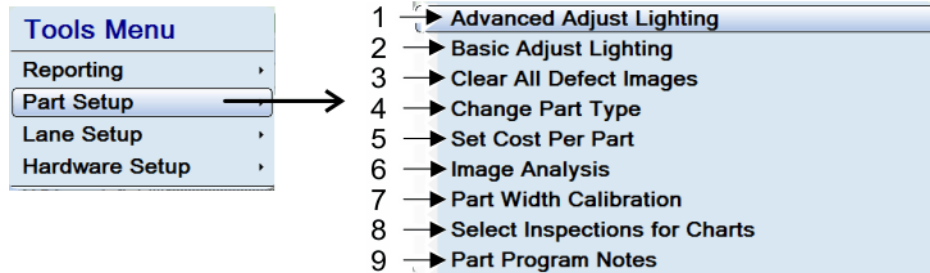

- 1) **Advanced Adjust Lighting**
- 2) **Basic Adjust Lighting**
- 3) **Clear All Defect Images** - Clear images from the Reject Images buffer.
- 4) **Change Part Type** - Select the type of part to be displayed on the Walk By Graphic for the current lane.
- 5) **Set Cost Per Part** - Set the cost of each product, to be used with the "Defect Cost" trend chart.
- 6) **Image Analysis** - Determine the gray shade value for any pixel or group of pixels in your image.
- 7) **Part Width Calibration** - Set the number of encoder ticks that the part detect sensor "sees" the part.
- 8) **Select Inspections For Charts** - Select which inspections (up to 8) to display on the Trend Chart and Timing Trend.
- 9) **Part Program Notes** - Add setup and program information about the part. This is helpful if you need to modify the part program later.

## Part Rate

The part rate is displayed in Lane Overview and Sensor Overview modes. You can reset the part rate by right-clicking over the part rate tab and selecting **Reset Part Rate**.

The part rate displays:

- **ppm (parts per minute)** - The average rate over the last five seconds. It is updated once per second.
- **max** - The maximum rate found for all individual parts in the last five seconds determined in [A]. The displayed value is the largest value found in the last five seconds.

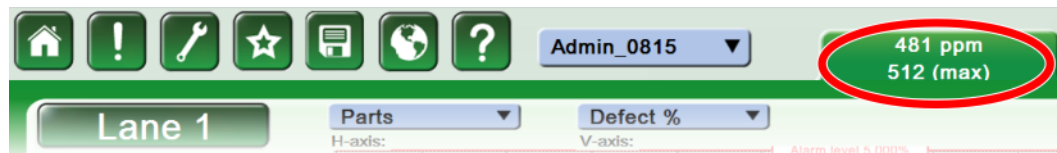

# Lane Setup

Some menu items are only available to advanced level users.

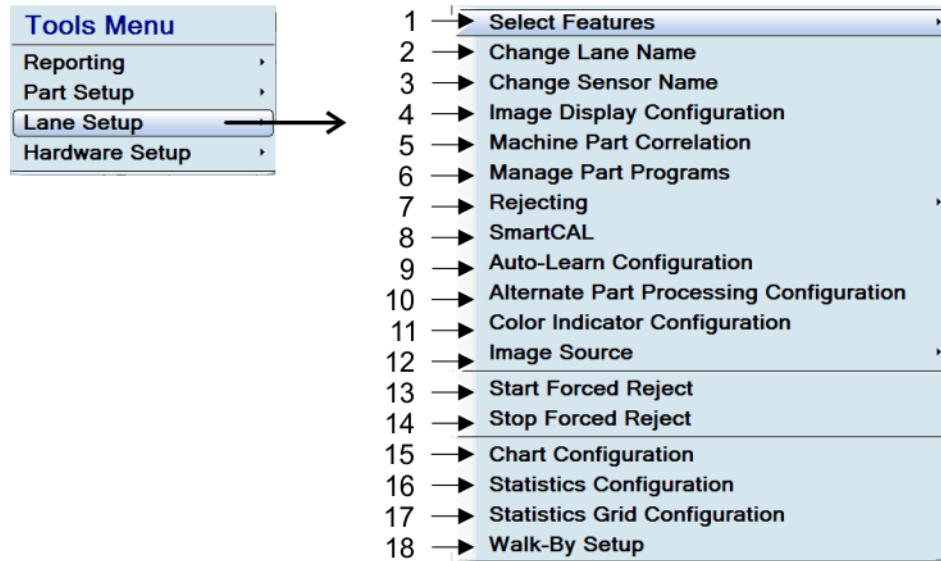

Some menu items are only displayed if enabled through **Select Features**.

- 1) **Select Features** - Enable optional features.
- 2) **Change Lane Name**
- 3) **Change Sensor Name**
- 4) **Image Display Configuration** - Set the display options for the sensor images.
- 5) **Machine Part Correlation** - Configure up to four different machine parts for correlation. [if Correlation is enabled] (This is usually done by the Pressco installer)
- 6) **Manage Part Programs**
- 7) **Rejecting** - Reject setup
- 8) **SmartCAL** - Run a set of images on the current part program, and make sure the part program is passing or rejecting parts as you expect.
- 9) **Auto-Learn Configuration** - [if you have an Extended I/O board, and Auto-Learn = enabled] Configure the Extended I/O bits to use with Auto-Learn.
- 10) **Alternate Part Processing** - Process the first N parts different than normal when your machine starts back up (after you stop it).
- 11) **Color Lane Indicator** configuration - Identify a lane by use of color.
- 12) **Image Source** - Select images to display on the lane.
- 13) **Start Forced Reject** (on page 105) - Force parts to be rejected based on correlation to a specific machine part.
- 14) **Stop Forced Reject**
- 15) **Chart Configuration** – Set the Trend Chart columns and currency type in "Cost Per Part."
- 16) **Statistics Configuration** - Change the display settings for the charts displayed by the Statistics buttons.
- 17) **Statistics Grid Configuration** - Change the amount of information for the charts displayed by the Statistics buttons.
- 18) **Walk By Setup** - Set the group names, groups of inspections, and the criteria to turn the part graphic green, yellow, or red.

# Forced Reject

Force any part to be rejected. The system will reject all parts associated with the selected components, regardless of the pass/fail condition. This can be used to handle an emergency situation until repairs on a blow-molder or other machine can be made, among other uses.

❖ *Note: the correlation check boxes and machine parts are only displayed if your machine is using correlation.*

To get to this screen: From Lane or Sensor Overview mode, select Tools  | Lane Setup | Start Forced Reject.

❖ *Note: the lane must be online to force rejects*

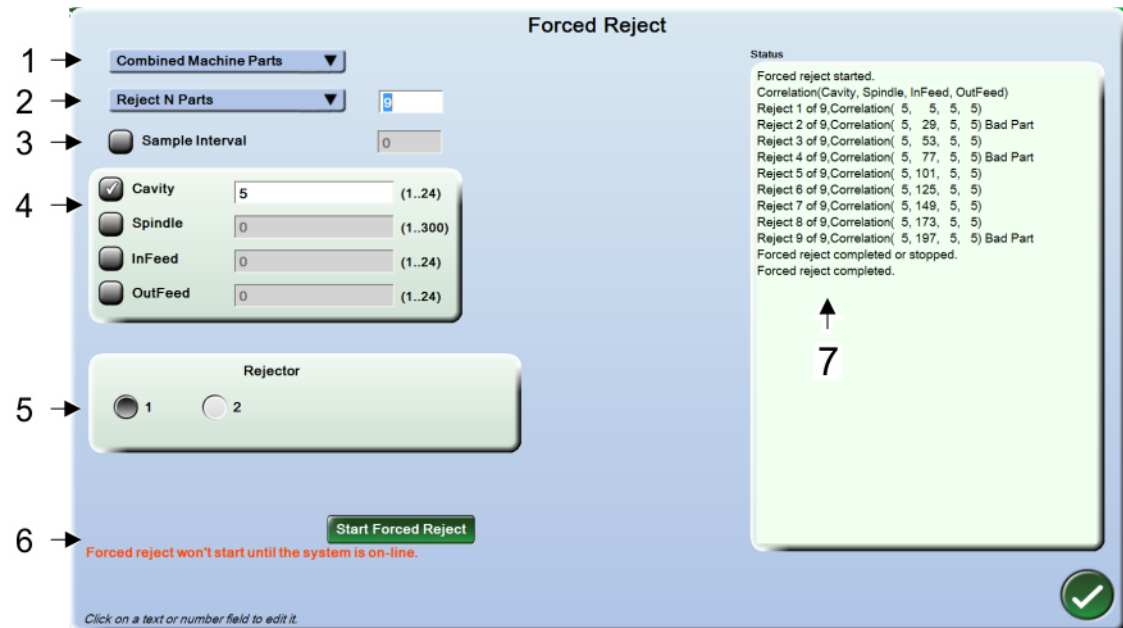

## 1) Any Part/ Single Machine Part/ Combined Machine Parts (drop-down menu)

**Any Part** - Reject any part, regardless of correlation to a machine part.

**Single Machine Part** - Reject a part or parts correlated to one machine part (example: cavity, or fill valve). You can enter multiple values, such as Cavity 5-7, 11. Use the keypad.

**Combined Machine Parts** - All correlated machine parts are displayed (as in the example above). Check the boxes next to the desired machine parts. Only one correlation value per machine part is allowed (example, Cavity 2 and Spindle 7). Use the keypad.

❖ *Note: Combined Machine Parts is an AND function. The part must be correlated to each machine part and number entered. If there are no such parts, then none will be rejected.*

## 2) Reject One Part/ Reject N Parts/ Continuous Reject (drop-down menu)

Reject one part, 'N' parts, or continuously reject from a specific machine part. Select the **Start Forced Reject** button to begin rejecting. If you select Single or Combined Machine Parts in the above drop-down menu, the part(s) must meet that criterion.

**Reject One Part** - Reject the next part that reaches the reject station, regardless of inspection status.

**Reject N Parts** - Enter a number of parts you want to reject, regardless of inspection status.

**Continuous Reject** - Reject all parts regardless of inspection status, until you select the **Stop Forced Reject** button.

## 3) Sample Interval

Only reject parts every n number of intervals. If you enter **3 Revolutions**, then the system will reject parts on every third revolution. If you select Single or Combined Machine Parts in the first drop-down menu, the part(s) must meet that criterion.

#### 4) - Select Machine Part

The names of your machine part components [only shown if you select Single or Combined Machine Parts in the first drop-down menu].

#### 5) Rejector

(Not shown - only applicable with multiple rejectors) Specify which rejector to force rejection of the part.

#### 6) Start Forced Reject/ Stop Forced Reject

When you select **Start Forced Reject**, the criteria specified are applied and the parts are rejected. Select the **Stop Forced Reject** button to stop the reject process. Note that if you only reject one part, or specify a number of parts, the button toggles back to **Start Forced Reject** automatically.

#### 7) Status Box

Displays information about the rejection process.

# Chapter 13

## Maintenance Frequency - Integrated Tunnel

Follow the guidelines for cleaning and maintenance of the Intellispec system and the inspection modules.

- For FHCP 3X systems, refer to System Guide Series V FHCP 3X
- For Compact Single Lane systems, refer to System Guide Series V CSL

Intellispec Processor Cabinet and General Components			
Item	Description	Once per day or shift	Once per month
Observe Proper inspection	Verify that defective parts are being rejected by inserting a known defective part through inspection	X	
Observe Proper inspection	Verify that no stray parts are stuck in or near the inspection module or reject station	X	
Observe Proper inspection	Verify that no buildup of dirt or contaminants has occurred on inspection module, part detector, or conveyor. Clean if necessary.	X	
Observe Proper inspection	Verify that each camera's image is properly centered, focused, and properly lit. Adjust if necessary.	X	
Vision Processor filter	Rinse in clean water; use mild soap and water solution if oily. <b>Cleaning the Vision Processor filter</b> (on page 108)		X
Cluster Box filters (if applicable)	Rinse in clean water; use mild soap and water solution if oily. <b>Cleaning the Cluster Box filters</b> (on page 109)		X

Inspection Modules Chromapulse			
Item	Description	Once per day or shift	Once per month
Part Detect Sensor and Reflector	Clean with soft, clean, oil-free cloth dampened with mild soap and water solution. Wipe dry. <b><i>Cleaning the Part Detector</i></b> (on page 114)	Once per week	
Camera lens	Clean only with lens tissue and lens cleaner. Be careful not to alter focus or aperture. <b><i>Cleaning the Camera Lens</i></b> (on page 113)		X
Glass surfaces: Beam Splitter and Secondary lens	Clean with soft, clean, oil-free cloth dampened with lens cleaning solution. <b><i>Cleaning the Chromapulse Beam Splitter</i></b> (on page 112)		X
Ellipsoidal mirror	Normally does not need cleaning. If dirty, blow off dust with clean, compressed air. <b><i>Cleaning the Ellipsoidal Mirror</i></b> (on page 114)		Only if dirt appears on image
Plastic surfaces: Dome light or Ring light diffusers	Clean with soft, clean, oil-free cloth dampened with mild soap and water solution. Wipe dry.		X
Fan filters CP4422EV	Rinse in clean water; use mild soap and water solution if oily. <b><i>Cleaning the Chromapulse Fan Filters</i></b> (see " <b><i>Replacing/ Cleaning the Chromapulse CP4422EV Fan Filters</i></b> " on page 110)		X
Filter/ Regulator	Replace filters <b><i>Replacing Filter/ Regulator Filters</i></b> (on page 115)	Oil removal filter - replace every <b>2000 hours</b> Oil vapor removal filter - replace every <b>12 months</b>	

## Cleaning the Vision Processor filter

The filter for the vision processor should be cleaned once a month for best results. The filter is located underneath the user interface cabinet. If the filter has holes or is too dirty to clean, then replace it with Pressco part number 66621.

❖ *Note: You may need to clean the filters weekly depending on plant conditions*

### ➤ **To clean the filter:**

1. Pull down the front of the grate [item 1] with your fingers.
2. Remove the filter [item 2] and clean it.
  - If the filter contains dry dust and dirt, rinse it in plain water
  - If the filter contains oily dust and dirt, clean it in soapy water, then rinse in clear water
3. Dry the filter completely, then place it back underneath the user interface cabinet.

4. Push the grate closed.

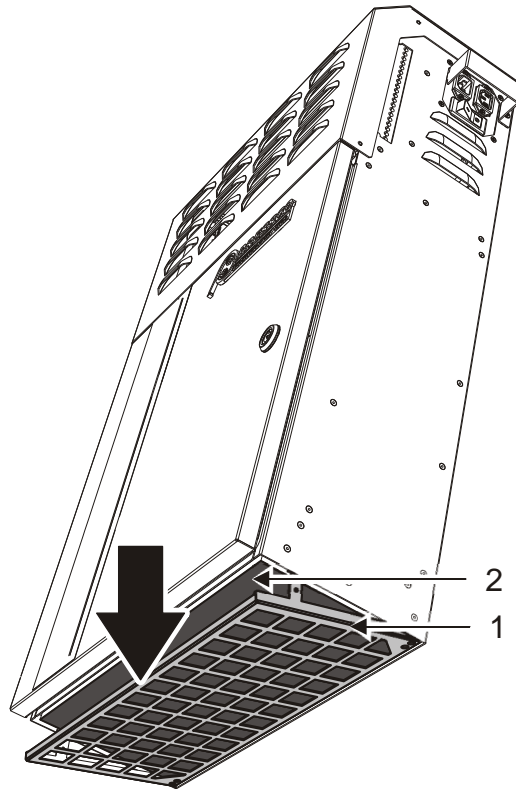

- 1) Grate to hold filter in place
- 2) Part number 66621 - filter for vision processor

---

## Cleaning the Cluster Box filters

Clean the filter on the vents when they get dirty. We recommend that you clean them at least once a month. Remove the covers to access the filters.

- If the filter contains only dry dust and dirt, rinse it in plain water
- If it contains oily dust and dirt, clean it in soapy water

- Dry the filter completely before reinstalling it

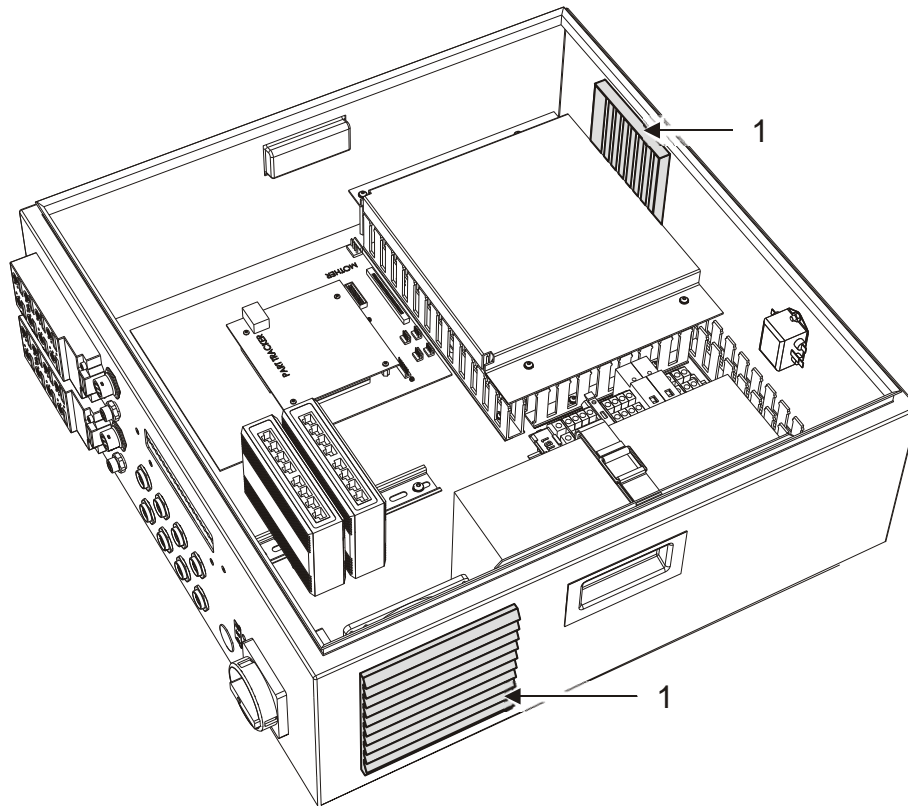

❖ *Note: the illustration shows a Classic cluster box. However, all types of cluster boxes use the same filter replacement.*

To replace a filter, use the part number listed below:

	<b>Part Number</b>	<b>Description</b>
1	65779	Replacement filter element (same part number is used in both locations)

## **Replacing/ Cleaning the Chromapulse CP4422EV Fan Filters**

Replace the filters once a month, using part number 66446.

If you do not have replacement filters, clean them once per month. Remove the covers to access the filters.

- If the filter contains only dry dust and dirt, rinse it in plain water
- If it contains oily dust and dirt, clean it in soapy water

- Dry the filter completely before reinstalling it

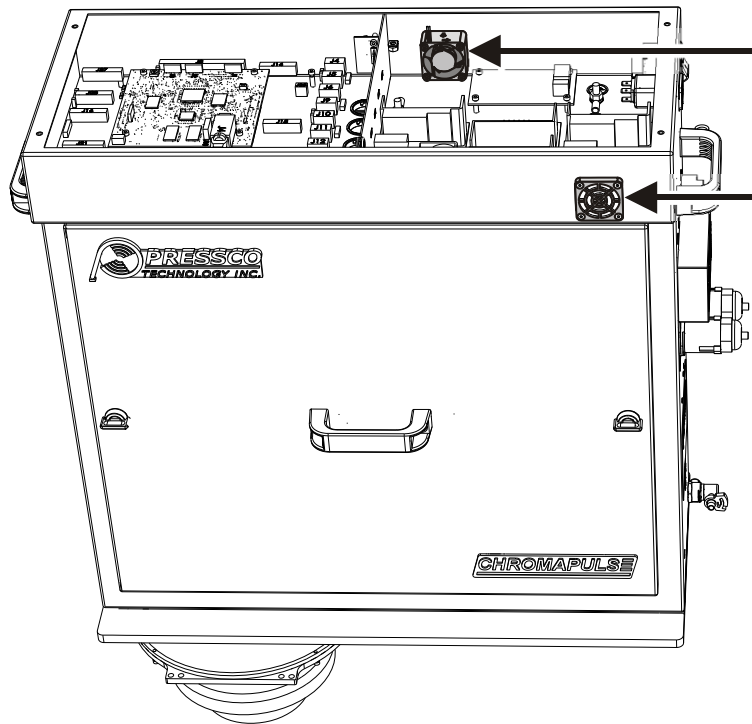

To replace a filter, use: Part number - 66446: Replacement filter element (same part number is used in both locations)

---

## Cleaning Optical Surfaces



Important - Debris and contamination could build up on both the glass and plastic surfaces. This dirt could appear in the inspection windows, causing false rejects of parts, or it could degrade lighting. Clean glass and plastic surfaces often to avoid false rejects.

To maintain proper image quality and system performance, the clear glass and plastic surfaces on the Inspection Modules must be cleaned on a regular basis. Dirt and debris that appear in the image can cause false rejects. An oily film on optical surfaces can cause false rejects or missed defects.

---

## Cleaning Glass Surfaces

Glass surfaces that may require cleaning are:

- Camera Lens
- Beam Splitter (if present)
- Secondary lens (if present)
- Secondary mirror (if present)

➤ **To clean glass surfaces:**

- Blow off dust with canned, compressed air
- Use a clean non-abrasive cloth dampened with lens cleaning solution
- Use lens tissue and lens cleaning solution on camera lenses
- If surface has compound on it, first clean with alcohol, then with lens cleaning solution

❖ *Note: Cleaning frequency will depend on plant and process conditions.*

---

## Cleaning the Chromapulse Beam Splitter

You must remove the Beam Splitter (on some Chromapulse models) to access the bottom side for cleaning. The method for removing the beam splitter depends on your inspection module.

In the illustration below, item A is used in preform sidewall endcap (PSE) modules. Item B is used in seal surface modules and some Chromapulse modules (example: CP750EV, CP1200EV, and more).

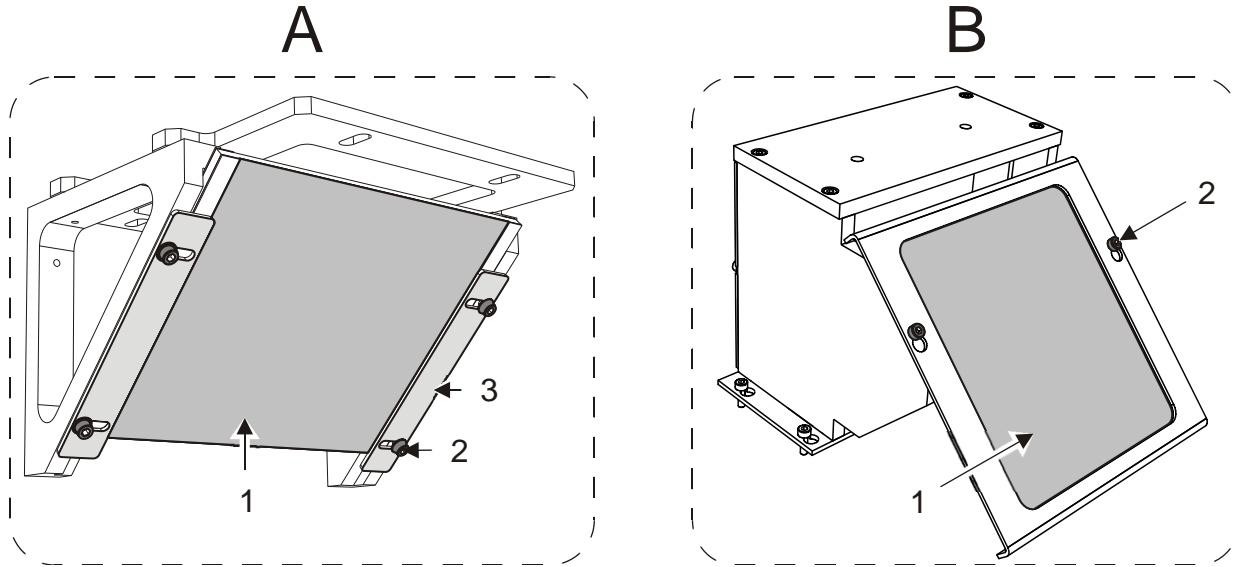

- 1) Beam Splitter
- 2) Screws
- 3) Retaining plates

### ➤ **To clean beam splitter:**

1. **Raise the camera** (see "**Cleaning the Camera Lens**" on page 113) if necessary. Be sure to note the camera position before moving it.
2. Loosen the screws [item 2] and carefully remove the beam splitter.
  - **Item A** has four screws. Slide the retaining plates [item 3] to the sides and remove the beam splitter.
  - **Item B** has two screws. Loosen the screws to remove the beam splitter.
3. Clean the beam splitter [item 1].
  - Blow off dust from beam splitter with canned, compressed air.
  - **Clean the glass** (see "**Cleaning Glass Surfaces**" on page 111) on the beam splitter using lens tissue and lens cleaner.
4. Replace the beam splitter assembly.
  - **Item A** - Replace the beam splitter with the reflective side to the outside. Slide the retaining plates back in plates and tighten the screws.
  - **Item B** - Replace the beam splitter with glass to the inside. Tighten the screws.

## Cleaning the Camera Lens



Caution - Do not touch the lens with fingers or oily cloths.

### ➤ To clean the camera lens:

1. Raise the camera to access the lens by loosening the height adjustment screw [item 1].
2. Leave the clamping bracket in place [item 2].
3. Clean all camera lenses with lens tissue and lens cleaning fluid. Be careful not to alter the focus or aperture of the cameras.
4. Slide the camera back into position as marked by the clamping bracket.
5. Tighten the height adjustment screw
6. Re-adjust aperture and focus if needed.

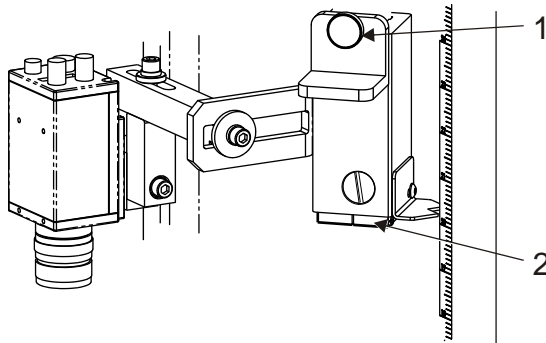

- 1) Camera height adjustment screw
- 2) Clamping bracket - camera height reference

## Cleaning Plastic Surfaces

Plastic surfaces that may require cleaning are:

- Dome Light Diffuser
- Ring Light Diffuser
- Light Shield (if present)
- Beam Splitter Diffuser (if present)

❖ *Note: Cleaning frequency will depend on plant and process conditions.*

### ➤ To clean plastic surfaces:

Do	Do Not
Use canned compressed air to blow away dust	Do not wipe away dirt as plastic coating may be scratched
Use a clean, non-abrasive cloth dampened with mild soap and water solution. Saturate surface completely to let particles wash away.	Do not use paper towels or paper napkins – these may scratch surfaces
Dry the surface with clean, compressed air	

---

## Cleaning the Ellipsoidal Mirror

This mirror provides the enhanced neck image for optimal inspection of the neck of a can.



Warning - The special surface of the mirror can be easily scratched. Take special precautions and do not touch the surface of the mirror.

---

- ❖ *Note: This mirror does **not** require periodic cleaning. Contact Pressco Service if the mirror has dirt or marks that cannot be blown off with clean, compressed air.*
- 

In most systems, the mirror has a built-in air cleaning system. Air is blown through the module to keep dust and debris off the mirror and out of the module. There are no bottom shields on these modules. You do not have to clean the mirror in these modules.

---

## Cleaning the Part Detector

Your system will be equipped with either a part detector or proximity sensor, depending on your application. The proximity sensor does not use a reflector. However, the cleaning procedure for either of these types of sensors is similar.

The part detect sensor and reflector surfaces of the part detector must remain clean to properly detect parts. Clean these surfaces regularly to prevent dirt and oil build-up.

➤ **To clean the part detector:**

- Clean the part detector surfaces with a soft, clean, lint-free cloth dampened with a mild soap and water solution
  - Clean the sensors on both sides of the conveyor
  - Do not use a glass cleaning solution or strong solvent on plastic surfaces as they might be damaged.
- 

- ❖ *Note: The frequency of cleaning will depend on plant and process conditions.*
- 

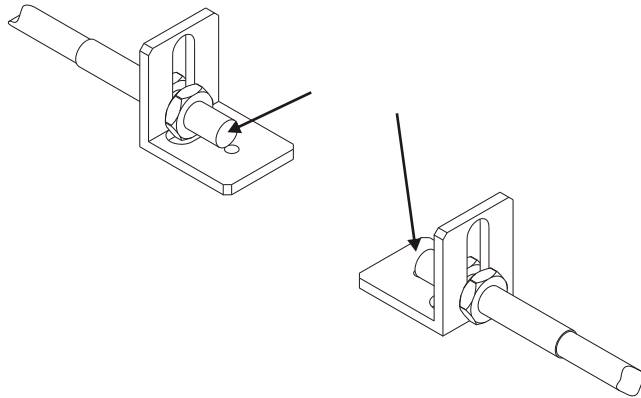

---

## Cleaning the Part Detector and Reflector

The part detect sensor and reflector surfaces of the part detector must remain clean to properly detect parts. Clean these surfaces regularly to prevent dirt and oil build-up.

Clean the part detector surfaces with a soft, clean, lint-free cloth dampened with a mild soap and water solution. Do not use a glass cleaning solution or strong solvent on the plastic surfaces as they might be damaged.

The frequency of cleaning will depend on plant and process conditions.

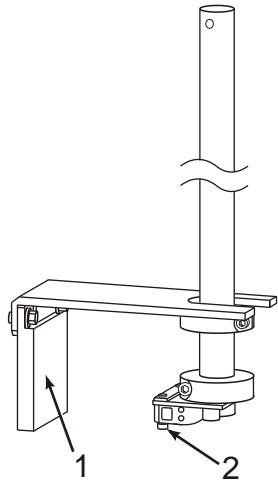

- 1) Part detect reflector
- 2) Part detect sensor

---

## Replacing Filter/ Regulator Filters

The filter/ regulator assembly shown below is installed with CP4422EV inspection modules. Replace filters.

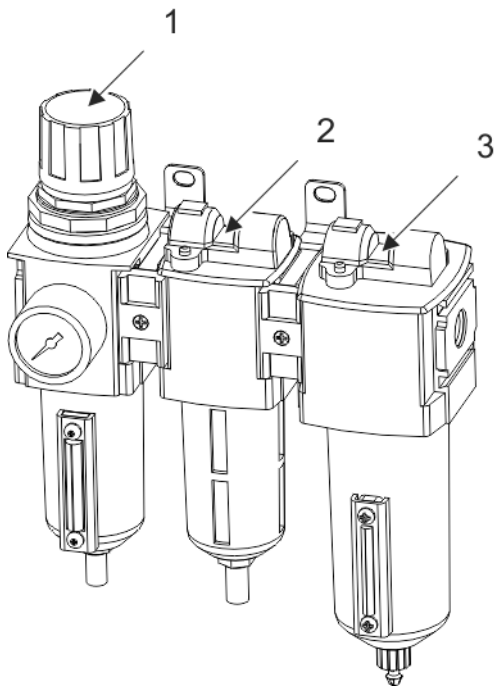

	<b>Pressco part number</b>	<b>Description</b>	<b>Replace at least:</b>
1		Filter/ regulator. No filter change necessary.	
2	67620	Filter oil removal	Every 2000 hours
3	67621	Filter oil vapor removal	Once per year
	<b>67622</b>	Kit (contains one each of 67620 and 67621) <ul style="list-style-type: none"> <li>▪ It is easier to replace both of these filters at the same time</li> </ul>	

# Index

## 8

8 PORT I/O BOXES • 51

## A

ABOUT THIS OPERATOR'S GUIDE • 7

ALARMS • 19, 75

ASSEMBLY, LOCATION, AND MOUNTING  
REQUIREMENTS • 39

AUTHORIZED USERS • 23

AUTO-SAVE IMAGES • 96

AUTO-SAVE IMAGES • 96

## B

BASE CAMERA MODULE DIMENSIONS SERIES V • 29

BASE, NECK, AND SEAL INSPECTION MODULE WEIGHTS  
• 29

BASE/NECK MAST DIMENSIONS SERIES V • 30

BIOMETRIC LOGIN DEVICE • 66

## C

CHANGE YOUR PASSWORD • 73

CHROMAPULSE MODULE EXTERNAL CONNECTIONS •  
47

CLASSIC CLUSTER BOX EXTERNAL CONNECTORS • 50

CLASSIC CLUSTER BOX MEASUREMENTS • 34

CLEANING GLASS SURFACES • 111

CLEANING OPTICAL SURFACES • 111

CLEANING PLASTIC SURFACES • 113

CLEANING THE CAMERA LENS • 113

CLEANING THE CHROMAPULSE BEAM SPLITTER • 112

CLEANING THE CLUSTER BOX FILTERS • 109

CLEANING THE ELLIPSOIDAL MIRROR • 114

CLEANING THE PART DETECTOR • 114

CLEANING THE PART DETECTOR AND REFLECTOR • 115

CLEANING THE VISION PROCESSOR FILTER • 108

CLEAR STATISTICS • 69

CLUSTER BOX ELECTRICAL SPECIFICATIONS • 33

CLUSTER BOX EXTERNAL CONNECTIONS • 48

CLUSTER BOX MAINS WIRING • 48

CLUSTER BOX SERIES V • 33

CLUSTER BOX SYSTEM CONFIGURATIONS • 54

COMMISSIONING • 56

CORRELATION REPORT • 101

CP/EV MODULE MEASUREMENTS • 28

## D

DECLARATION OF CONFORMITY - CLUSTER BOX • 13

DECLARATION OF CONFORMITY - CPX INSPECTION  
MODULE • 15

DECLARATION OF CONFORMITY - CSL SYSTEM • 10

DECLARATION OF CONFORMITY - EMBEDDED CLUSTER  
BOX • 14

DECLARATION OF CONFORMITY - FHCP3X-EZ SYSTEM  
(EMC) • 12

DECLARATION OF CONFORMITY - FHCP3X-EZ SYSTEM  
(MS) • 11

DECLARATION OF CONFORMITY - INTELLIMASS • 16

DECLARATION OF CONFORMITY - INTELLISPEC SYSTEM  
• 9

## E

ELECTRICAL CONNECTION • 40

EMBEDDED CLUSTER BOX EXTERNAL CONNECTIONS •  
52

EMBEDDED CLUSTER BOX MEASUREMENTS • 35

ENVIRONMENTAL CONDITIONS • 25

ERROR MESSAGES • 102

EU DECLARATIONS OF CONFORMITY • 9

EXITING THE INTELLISPEC SOFTWARE • 61

## F

FORCED REJECT • 105

FREEZE ON DEFECT • 90

FREEZE ON DEFECT OPTIONS MENU • 95

FREEZE ON DEFECT SETUP MENU • 93

## G

GRAPHS AND IMAGE DISPLAYS • 83

## H

HEALTH WARNINGS - PHOTSENSITIVE EPILEPSY • 17

HELP • 72

HOW TO SELECT MENU ITEMS • 64

## I

INSPECTIONS GRAPH • 89

INSTALLATION • 41

INSTALLATION AND WIRING • 37

INTEGRATED TUNNEL ELECTRICAL SPECIFICATIONS •  
27

INTELLISPEC CABINET AND USER INTERFACE • 63

INTENDED USE • 20

INTRODUCTION • 7

## L

LANE ALARMS - BRIEF DESCRIPTION • 78  
LANE SETUP • 104  
LANGUAGE • 71  
LIFTING HEAVY OBJECTS • 22  
LIGHT TREE • 19  
LOG IN AND LOG OUT • 73  
LOG READER • 99

## M

MACHINE PART ALARMS - BRIEF DESCRIPTION • 81  
MACHINE PART ALARMS - VIEW/CLEAR • 82  
MACHINE PART GRAPHS • 83  
MAINTENANCE FREQUENCY - INTEGRATED TUNNEL • 107  
MARKING • 18  
MECHANICAL KEYBOARD (MKB) • 65  
MENU TOOLBAR • 71  
MICRO AND WASH-DOWN CLUSTER BOX MEASUREMENTS • 35

## N

NECK/ SIDEWALL CAMERA DIMENSIONS SERIES V • 30

## O

ON SCREEN KEYBOARD (OSK) • 70  
ONLINE / OFFLINE • 61  
OPERATING THE INTELLISPEC SERIES V SYSTEM • 59

## P

PART CHANGEOVER • 61  
PART RATE • 103  
PART SETUP • 103  
PERSONAL PROTECTIVE EQUIPMENT • 20  
PERSONNEL SAFETY • 21  
POWER DOWN • 60  
POWER UP • 59  
PERFORM SEAL ENDCAP INSPECTION MODULE DIMENSIONS • 32  
PERFORM SIDEWALL INSPECTION MODULE DIMENSIONS • 32  
PRESSCO PC OUTLET WIRING • 44  
PROHIBITED USE • 20  
PROTECTIVE EARTHING • 40

## R

RECOMMENDATIONS PRIOR TO INSTALLATION • 37

REJECT IMAGES • 88  
REJECTOR ALARMS - BRIEF DESCRIPTION • 80  
REPLACING FILTER/ REGULATOR FILTERS • 115  
REPLACING FUSES IN THE CLUSTER BOX • 55  
REPLACING/ CLEANING THE CHROMAPULSE CP4422EV FAN FILTERS • 110  
REPORTING • 100  
RESIDUAL RISK • 20

## S

SAFETY INFORMATION • 17  
SAVE IMAGES THROUGH THE SENSOR MENU • 96  
SAVE REJECT IMAGES • 97  
SAVING IMAGES • 95  
SEAL SURFACE INSPECTION MODULE DIMENSIONS SERIES V • 31  
SENSOR ALARMS - BRIEF DESCRIPTION • 79  
SENSOR MISSED STATISTICS • 102  
SHIPPING AND HANDLING • 37  
SOFTWARE OVERVIEW • 67  
SORT DATA IN GRAPHS • 84  
SOUND PRESSURE LEVEL • 25  
SPARE PARTS USAGE • 23  
SPECIFICATIONS • 25  
STABILITY OF USER INTERFACE • 41  
STATIC DISCHARGE PROTECTION • 8  
STATISTICS GRID • 86  
STATISTICS GRID OPTIONS • 87  
STATISTICS MENU • 69  
SWITCH USERS • 73  
SYMBOLS • 18  
SYSTEM ALARMS - DESCRIPTION AND CONFIGURATION • 77  
SYSTEM BLOCK DIAGRAM - BNS • 38  
SYSTEM BLOCK DIAGRAM - INTEGRATED TUNNEL • 39  
SYSTEM SPECIFICATIONS • 25

## T

TAKE SCREEN SHOT • 97  
TOOLS MENU • 99  
TOOLS MENU - LANE OVERVIEW AND SENSOR OVERVIEW SCREENS • 100  
TOOLS MENU - SYSTEM OVERVIEW SCREEN • 99  
TREND GRAPHS • 83  
TYPES OF CLUSTER BOXES • 48  
TYPOGRAPHICAL CONVENTIONS • 7

## U

- USB PORTS • 65
- USER ACCOUNTS AND LOGIN INFORMATION • 73
- USER INTERFACE • 26
- USER INTERFACE DISPLAY - FOUR LEVELS • 67
- USER INTERFACE ELECTRICAL SPECIFICATIONS • 26
- USER INTERFACE EXTERNAL CONNECTIONS • 42
- USER INTERFACE INPUT DEVICES • 63
- USER INTERFACE MEASUREMENTS • 27
- USER INTERFACE SELECTION DEVICES • 64
- USING THE WALK BY GRAPHIC • 90
- UTILITIES TO BE SUPPLIED BY CUSTOMER • 39

## V

- VENTILATION • 41
- VIEW/ CLEAR ALARMS • 75

## W

- WALK BY GRAPHIC • 89
- WARNING DEVICES • 19
- WASH-DOWN AND MICRO CLUSTER BOX EXTERNAL CONNECTIONS • 53
- WIRING DIAGRAM ETHERNET SWITCHES • 46
- WIRING DIAGRAM USER INTERFACE/ PC • 45